



# SERVICE BULLETIN

GLOBAL AFTER SALES OFFICE, MITSUBISHI MOTORS CORPORATION

PURPOSE : CORRECTION	ISSUE NO. : MSB-12E55-501A	DATE : 2012-05-30
SUBJECT : A/C DIAGNOSIS CODE		<MODEL> (EUR) <span style="float:right">&lt;M/Y&gt; 11/12</span>
GROUP : HEATER AIR CONDITIONER		i-MiEV(HA3W)

## 1. Description:

An incorrect description about the A/C diagnosis codes B1105,B1108,B1109 and B1110 have been found in the applicable Service Manual. This contains the corrected information.

## 2. Applicable Manual :

Destination	Applicable manual	Pub. No.	Applicable title(INFO ID)	Content
EU	2011 i-MiEV WORKSHOP MANUAL	EUR: CHAE11 E1-CD( Eng) CHAF11 E1-CD( Fre) CHAG11 E1-CD( Ger) CHAS11 E1-CD( Spa) CHAI11 E1-CD( Ita)	Code No. B1105 Electric compressor (communication) (M550-10-070-01900-01) Code No. B1108 Electric water heater fail 1 (M550-10-100-01300-01) <11MY (EU)> (M550-10-100-02400-01) <12MY (EU)> Code No. B1109 Electric water heater fail 2 (M550-10-110-01000-01) <11MY (EU)> (M550-10-110-02100-01) <12MY (EU)> Code No. B1110 Electric water heater fail 3 (M550-10-120-01700-01) <11MY (EU)> (M550-10-120-02800-01) <12MY (EU)>	Attached sheet 9~16
	2012 i-MiEV WORKSHOP MANUAL	EUR: CHAE12 E1-CD( Eng) CHAF12 E1-CD( Fre) CHAG12 E1-CD( Ger) CHAS1 2E1-C D(Spa ) CHAI12 E1-CD( Ita)		

## 3. Details:

See Attached sheet 9-16



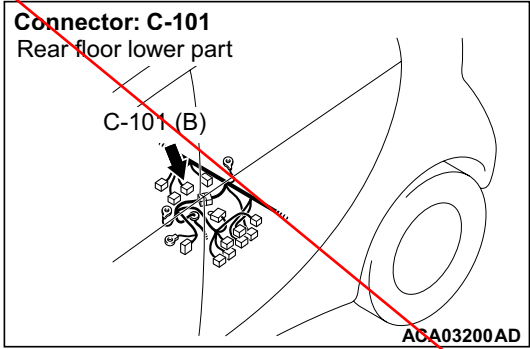

**DIAGNOSIS CODE SET CONDITIONS**

This code is set when the A/C compressor inverter cannot communicate with the compressor & heater controller for 5 seconds or more.

**PROBABLE CAUSES**

- Compressor & heater controller
- A/C compressor power supply
- Malfunction of A/C compressor
- Damaged harness wires and connectors

**DIAGNOSIS PROCEDURE**

**STEP 1. Connector check: C-101 A/C control unit connector and A-111 A/C compressor connector**

- Q: Is the check result normal?**  
**YES :** Go to Step 2.  
**NO :** Repair the damaged connector.

**STEP 2. Check the wiring harness between C-111 A/C compressor connector terminal No. 3 and A-101 A/C control unit connector terminal No. 11.**

- Check the input and output lines for open or short circuit.

*NOTE: Before checking the wiring harness, check the intermediate connector B-27 and repair it if necessary.*

- Q: Is the check result normal?**  
**YES :** Go to Step 3.  
**NO :** Repair the wiring harness.

**STEP 3. Check the wiring harness between C-101 A/C compressor terminal No. 1 and the fusible link (2).**

- Check the power supply line for open circuit.

- Q: Is the check result normal?**  
**YES :** Go to Step 4.  
**NO :** Repair the wiring harness.

**STEP 4. After replacing the compressor & heater controller, check again if the diagnosis code is set.**

- Q: Is the diagnosis code set?**  
**YES :** Replace the A/C compressor.  
**NO :** Intermittent malfunction. Refer to GROUP 00 – How to Use Troubleshooting/ Inspection Service Points, – How to Cope with Intermittent Malfunctions .)

<Incorrect>

Inset the attached sheet 10

Code No. B1105 ELC. compressor (communication)

A/C Compressor Circuit

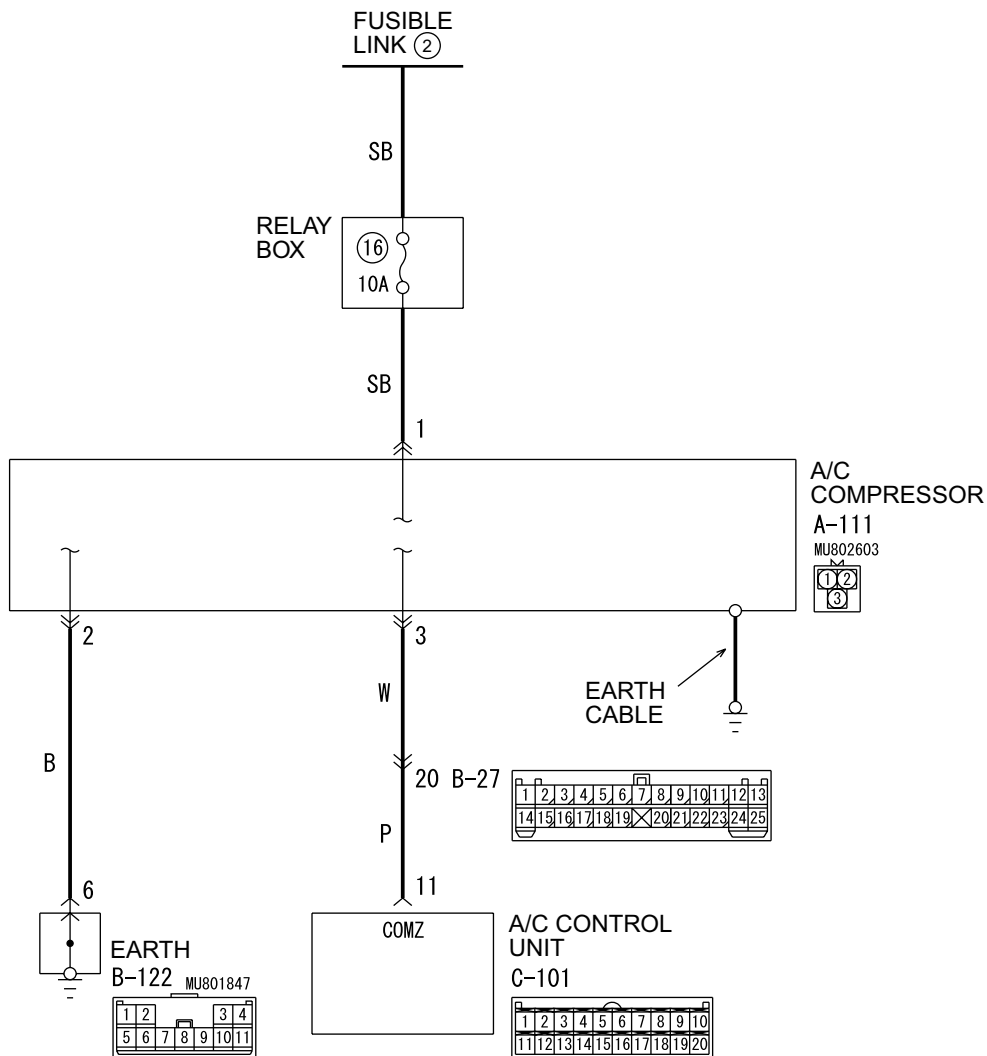

ACC00320  
WDT55M006A

Connector: A-111 <LHD>

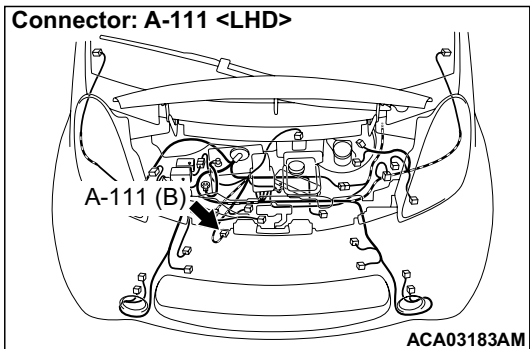

Connector: A-111 <RHD>

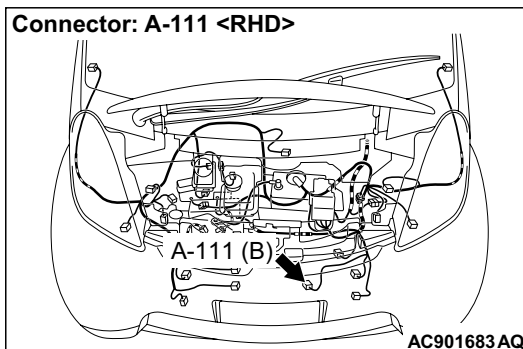

<Correct>

**Connector: C-101**  
Rear floor lower part

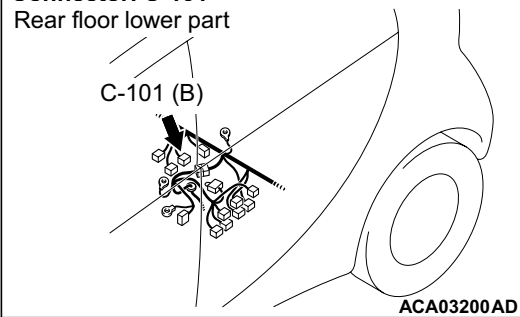

**Connector: B-122 <RHD>**

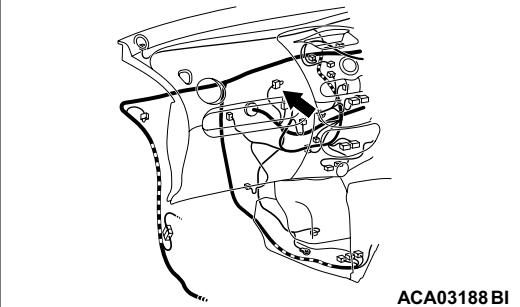

**Connector: B-122 <LHD>**

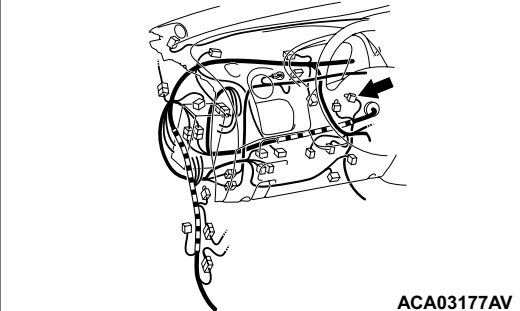

### Diagnosis code set conditions

This code is set when the A/C control unit cannot communicate with the compressor & heater controller for 5 seconds or more.

### PROBABLE CAUSES

- Malfunction of A/C control unit
- Malfunction of A/C compressor
- Damaged harness wires and connectors
- Power supply and earth to the A/C compressor defective

### DIAGNOSIS PROCEDURE

#### STEP 1. Connector check: C-101 A/C control unit and A-111 A/C compressor connector

**Q: Is the check result normal?**

**YES :** Go to Step 2.

**NO :** Repair the damaged connector.

#### STEP 2. Measure voltage at the A/C compressor connector A-111.

- (1) Disconnect the connector, and measure at the wiring harness side.
- (2) Voltage between terminal 1 and body earth

**OK: Battery voltage**

**Q: Is the check result normal?**

**YES :** Go to Step 4.

**NO :** Go to Step 3.

#### STEP 3. Check the wiring harness between the fusible link (2) and A-111 A/C compressor connector terminal No. 1.

- Check the power supply line for open circuit.

**Q: Is the check result normal?**

**YES :** Intermittent malfunction. (Refer to GROUP 00 – How to Use Troubleshooting/ Inspection Service Points, How to Cope with Intermittent Malfunctions .)

**NO :** Repair the wiring harness.

#### STEP 4. Measure resistance value at the A/C compressor connector A-111.

- (1) Disconnect the connector, and measure at the wiring harness side.
- (2) Resistance between terminal No. 2 and body earth

**OK: Continuity exists (2 Ω or less).**

**Q: Is the check result normal?**

**YES :** Go to Step 5.

**NO :** Go to Step 7.

#### STEP 5. Check the wiring harness between C-101 A/C control unit connector terminal No. 11 and A-111 A/C compressor connector terminal No. 3.

- Check the input and output lines for open or short circuit.

*NOTE: Before checking the wiring harness, check the intermediate connector B-27 and repair it if necessary.*

**Q: Is the check result normal?**

**YES :** Go to Step 6.

**NO :** Repair the wiring harness.

#### STEP 6. After replacing the A/C control unit , check again if the diagnosis code is set.

**Q: Is the diagnosis code set?**

<Correct>

**YES** : Replace the A/C compressor.  
**NO** : Intermittent malfunction. (Refer to GROUP 00 – How to Use Troubleshooting/ Inspection Service Points, How to Cope with Intermittent Malfunctions .)

---

**STEP 7. Connector check: B-122 grounding connector**

**Q: Is the check result normal?**

**YES** : Go to Step 8.  
**NO** : Repair the damaged connector.

---

**STEP 8. Check the wiring harness between A-111 A/C compressor connector terminal No.2 and B-122 grounding connector terminal No. 6.**

- Check the earth wires for open circuit.

**Q: Is the check result normal?**

**YES** : Intermittent malfunction. (Refer to GROUP 00 – How to Use Troubleshooting/ Inspection Service Points, How to Cope with Intermittent Malfunctions .)

**NO** : Repair the wiring harness.

<Correct>



A/C control circuit

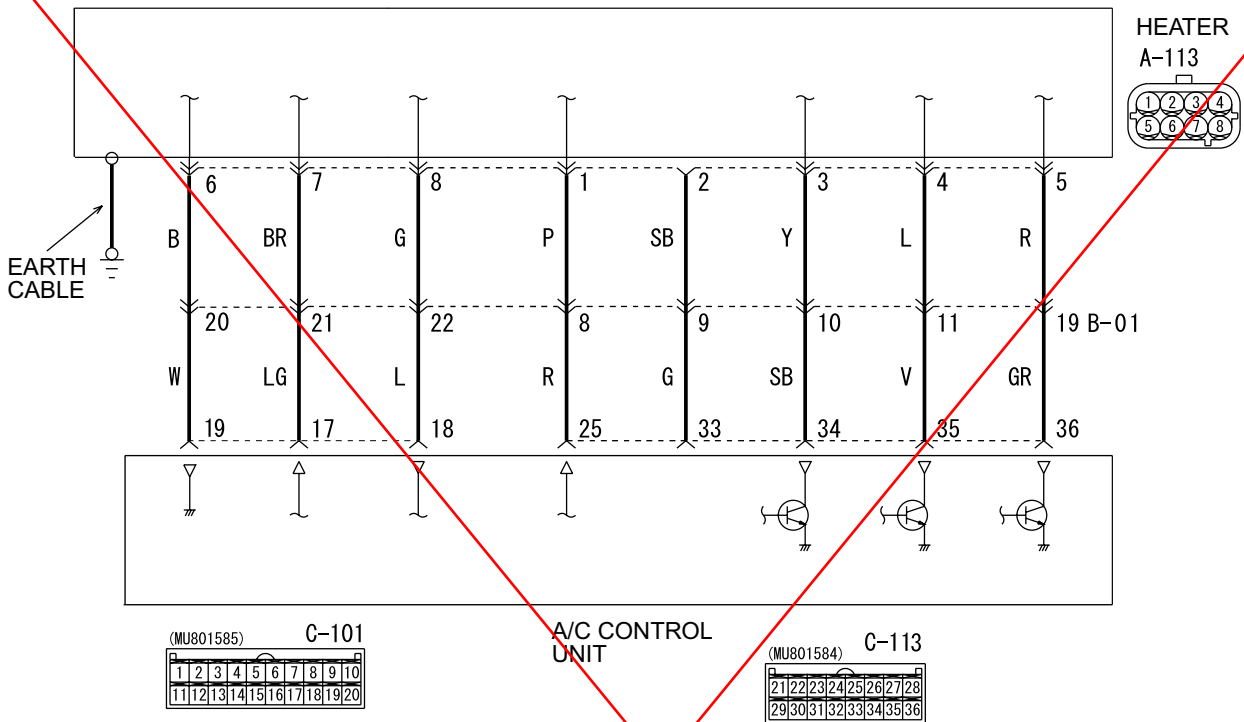

ACA04036

Wire colour code

B : Black LG : Light green G : Green L : Blue W : White Y : Yellow SB : Sky blue  
 BR : Brown O : Orange GR : Grey R : Red P : Pink V : Violet PU : Purple SI : Silver

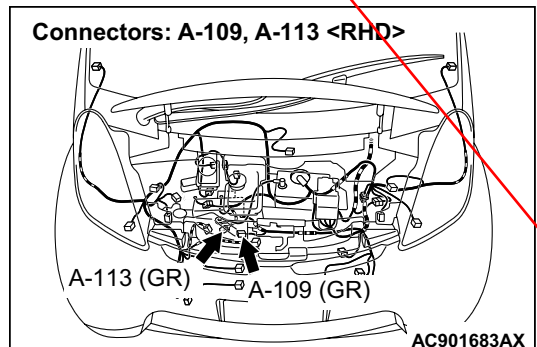
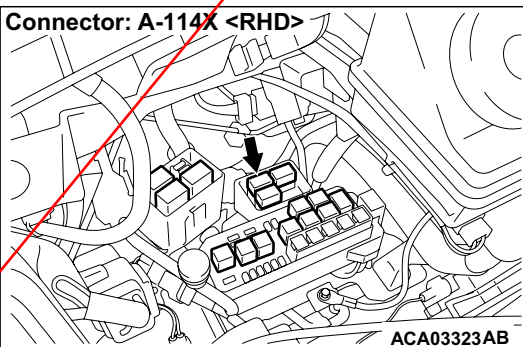
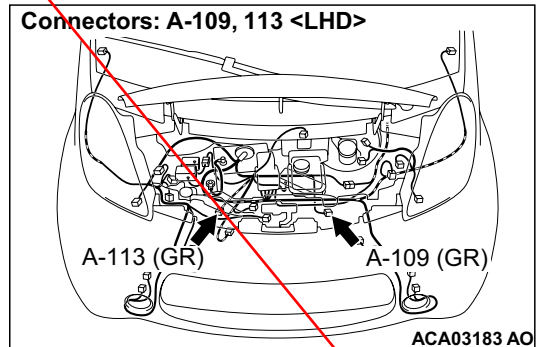
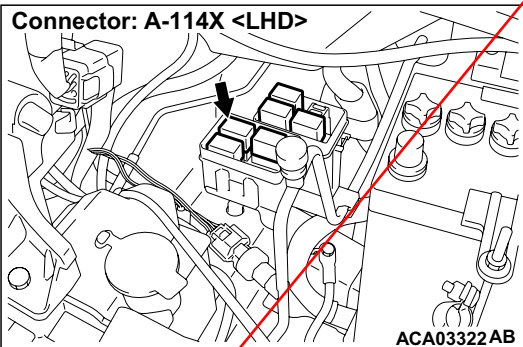

<Incorrect>

Inset the attached sheet 12



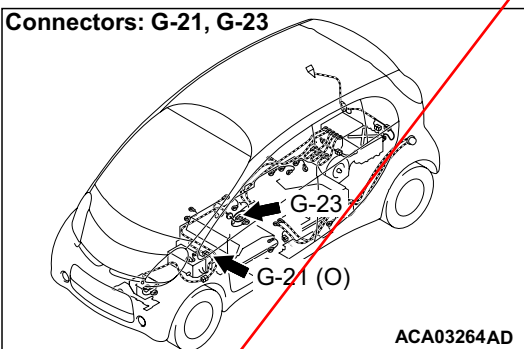
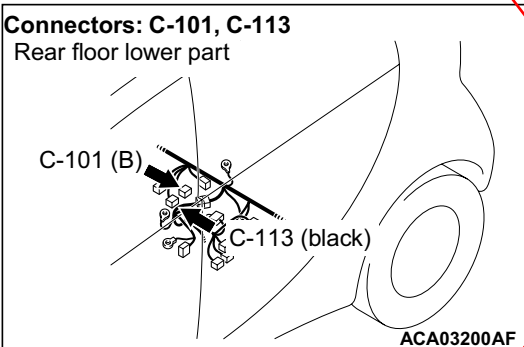
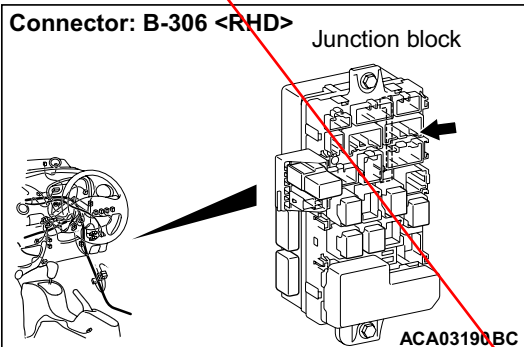
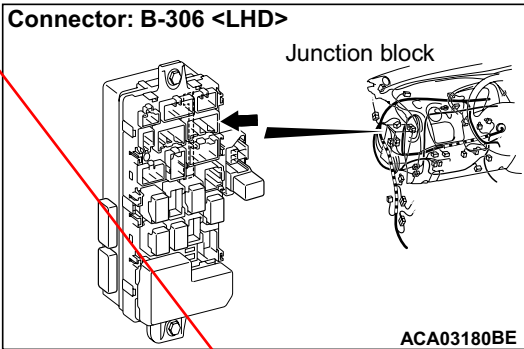

### DIAGNOSIS CODE SET CONDITIONS

This code is set when the outlet temperature of the heater does not raise to a temperature higher than the inlet temperature by 3°C or more for 30 seconds or more.

### PROBABLE CAUSES

- Insufficient volume of water heater fluid
- Malfunction of high-voltage fuse No. 3
- Poor connection of high-voltage fuse No. 3
- Malfunction of heater water pump assembly

- Malfunction of heater
- Damaged harness wires and connectors
- Malfunction of A/C control unit

## DIAGNOSIS PROCEDURE

### STEP 1. Check the water heater fluid volume.

Drive the heater in READY status and visually check the flow of the water fluid volume in the heater condenser tank.

**Q: Is the water heater fluid volume correct?**

**YES :** Go to Step 2.

**NO :** Make the water heater fluid volume correct.

### STEP 2. M.U.T.-III actuator test, service data

Check the results of the actuator test with the service data.

### ACTUATOR TEST

- Item 1: Electric water heater test mode

### DATA LIST

- Item 7: Electric water heater inspection

*NOTE: Because the heater test mode checks variations in the current, turn OFF the power supply to other equipment before the test.*

**Q: Is the check result normal?**

**YES :** Go to Step 3.

**NO :** Go to Step 22.

### STEP 3. Connector check: A-109 heater water pump assembly connector

**Q: Is the check result normal?**

**YES :** Go to Step 4.

**NO :** Repair the damaged connector.

### STEP 4. Check the heater water pump assembly.

Refer to .

**Q: Is the check result normal?**

**YES :** Go to Step 5.

**NO :** Replace the heater water pump assembly.

### STEP 5. M.U.T.-III data list

Check that the following service data display contents are normal.

- Item 8: Electric water pump output
- Item 10: Electric water heater inlet water temperature sensor
- Item 11: Electric water heater outlet water temperature sensor

**Q: Is the check result normal?**

<Incorrect>

YES : Go to Step 6.  
NO : Go to Step 22.

---

**STEP 6. Connector check: A-113 heater connector**

**Q: Is the check result normal?**  
YES : Go to Step 7.  
NO : Repair the damaged connector.

---

**STEP 7. Check the heater outlet water temperature sensor/heater inlet water temperature sensor.**

Refer to .

**Q: Is the check result normal?**  
YES : Go to Step 8.  
NO : Replace the heater.

---

**STEP 8. Connector check: A-114X heater water pump relay connector**

**Q: Is the check result normal?**  
YES : Go to Step 9.  
NO : Repair the damaged connector.

---

**STEP 9. Check the heater water pump relay.**

Refer to .

**Q: Is the heater water pump relay in good condition?**  
YES : Go to Step 10.  
NO : Replace the heater water pump relay.

---

**STEP 10. Measure the voltage at A-114X heater water pump relay connector.**

- (1) Disconnect the connector, and measure at the wiring harness side.
- (2) Voltage between terminal 4 and body earth

**OK: Battery voltage**

**Q: Is the check result normal?**  
YES : Go to Step 12.  
NO : Go to Step 11.

---

**STEP 11. Check the wiring harness between A-114X heater water pump relay connector terminal No. 4 and the fusible link (2).**

- Check the power supply line for open circuit.

**Q: Is the check result normal?**  
YES : Intermittent malfunction. Refer to GROUP 00 – How to Use Troubleshooting/ Inspection Service Points, – How to Cope with Intermittent Malfunctions .)  
NO : Repair the wiring harness.

---

**STEP 12. Measure the resistance at A-109 heater water pump assembly connector.**

- (1) Disconnect the connector, and measure at the wiring harness side.
- (2) Resistance between terminal No. 2 and body earth

**OK: Continuity exists (2 Ω or less)**

**Q: Is the check result normal?**  
YES : Go to Step 14.  
NO : Go to Step 13.

---

**STEP 13. Check the wiring harness between A-109 heater water pump assembly connector terminal No. 2 and the body earth.**

- Check the earth wires for open circuit.

*NOTE: Before checking the wiring harness, check the joint connector B-122 and repair it if necessary.*

**Q: Is the check result normal?**  
YES : Intermittent malfunction. Refer to GROUP 00 – How to Use Troubleshooting/ Inspection Service Points, – How to Cope with Intermittent Malfunctions .)  
NO : Repair the wiring harness.

---

**STEP 14. Check the wiring harness between A-104X heater water pump relay connector terminal No. 2 and B-305 junction block connector terminal No. 9.**

- Check the power supply line for open circuit.

**Q: Is the check result normal?**  
YES : Go to Step 15.  
NO : Repair the wiring harness.

---

**STEP 15. Connector check: C-101, C-115 A/C control unit connectors**

**Q: Is the check result normal?**  
YES : Go to Step 16.  
NO : Repair the damaged connector.

---

**STEP 16. Check the wiring harness between A-114X heater water pump relay connector terminal No. 1 and C-101 A/C control unit connector terminal No. 7.**

- Check the power supply line for open circuit.

*NOTE: Before checking the wiring harness, check the intermediate connector B-27 and repair it if necessary.*

**Q: Is the check result normal?**  
YES : Go to Step 17.  
NO : Repair the wiring harness.

**STEP 17. Check the wiring harness between A-114X heater water pump relay connector terminal No. 3 and A-109 heater water pump assembly connector terminal No. 1.**

- Check the power supply line for open circuit.

**Q: Is the check result normal?**

**YES :** Go to Step 18.

**NO :** Repair the wiring harness.

**STEP 18. Check the wiring harness between A-109 heater water pump assembly connector terminal No. 1 and C-115 compressor & heater controller connector terminal No. 29.**

- Check the input line for open circuit.

*NOTE: Before checking the wiring harness, check the intermediate connector B-27 and repair it if necessary.*

**Q: Is the check result normal?**

**YES :** Go to Step 19.

**NO :** Repair the wiring harness.

**STEP 19. Connector check: A-113 heater connector**

**Q: Is the check result normal?**

**YES :** Go to Step 20.

**NO :** Repair the damaged connector.

**STEP 20. Check the wiring harness between A-113 heater connector terminal connector terminal No. 6, 7, 8, 1, 3, 4, 5 and C-101 A/C control unit connector terminal No. 19, 17, 18, C-113 A/C control unit connector terminal No. 25, 34, 35, 36.**

- Check the input line for open circuit.

*NOTE: Before checking the wiring harness, check the intermediate connector B-01 and repair it if necessary.*

**Q: Is the check result normal?**

**YES :** Go to Step 21.

**NO :** Repair the wiring harness.

**STEP 21. Check the high-voltage connector and wiring harness.**

**⚠ DANGER**

**Carry out the check on the high-voltage circuit while reading carefully the precautions on handling a high-voltage vehicle. Refer to .**

**⚠ DANGER**

**Wear the specified protection equipment during the check.**

1. Shut down the high voltage. (Refer to GROUP 00 – Precautions before Service - Precautions on handling high-voltage vehicle .)
2. G-21 Check the heater connector.
3. G-23 Check the high-voltage fuse No. 3 connecting bolt for looseness.
4. Visually check and check the continuity of the high-voltage fuse No. 3.
5. Visually check the following high-voltage wiring harnesses for damage.
  - High-voltage wiring harness on main battery side
  - High-voltage harness heater side

**Q: Is the check result normal?**

**YES :** Go to Step 22.

**NO <Malfunction of high-voltage fuse No. 3> :**  
Replace the high-voltage fuse No. 3.

**NO <Malfunction of wiring harness on heater side> :**  
Replace the heater.

**NO <Malfunction of wiring harness on main battery side> :** Replace the main battery.

**STEP 22. Check whether the diagnosis code is reset.**

**Q: Is the diagnosis code set?**

**YES :** Go to Step 23.

**NO :** Intermittent malfunction. Refer to GROUP 00 – How to Use Troubleshooting/ Inspection Service Points, – How to Cope with Intermittent Malfunctions .)

**STEP 23. After replacing the compressor & heater controller, check again if the diagnosis code is set.**

**Q: Is the diagnosis code set?**

**YES :** Replace the heater.

**NO :** This diagnosis is complete.

<Incorrect>

Inset the attached sheet 12

Code No. B1108 Electric water heater fail 1

Heater water pump circuit

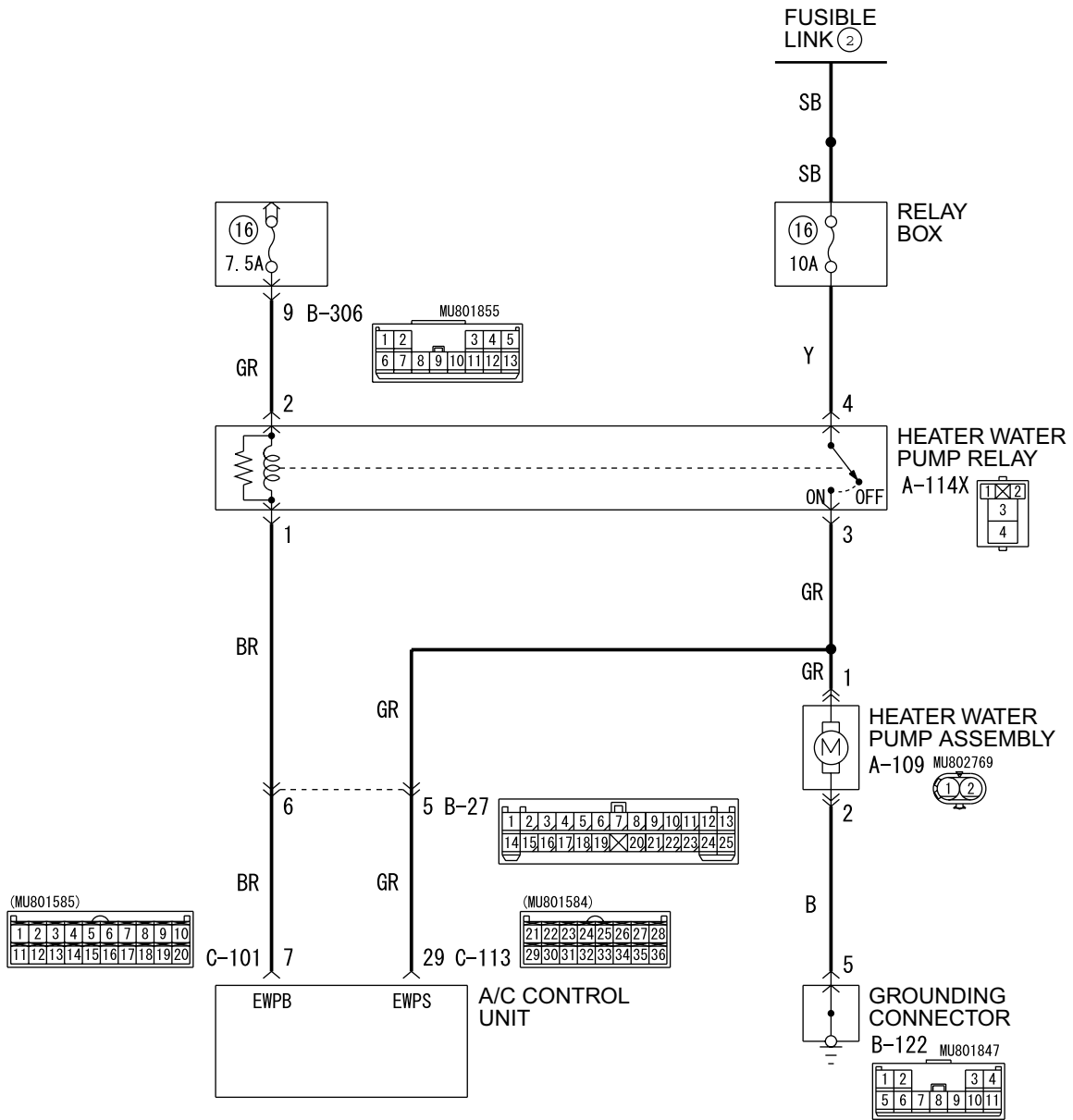

ACC00319  
WDT55M007A

<Correct>

A/C Control Circuit

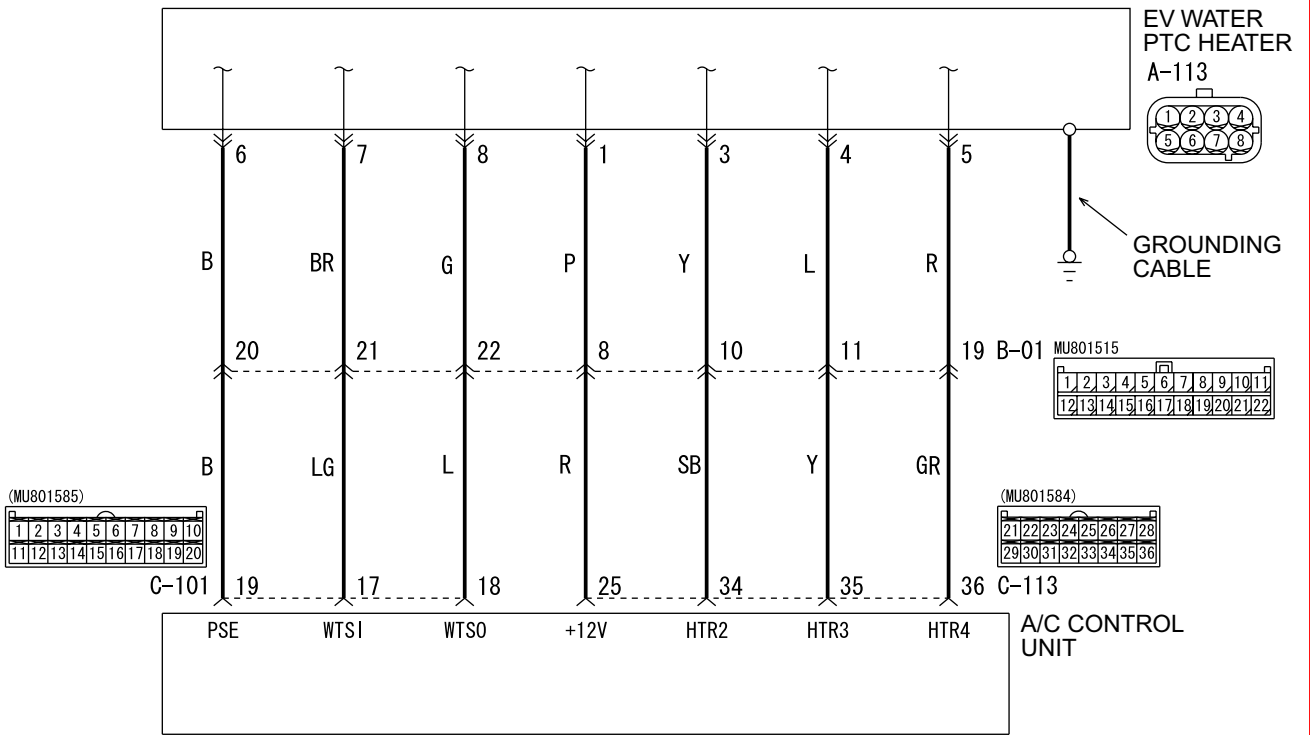

ACC00326  
WDT55M008A

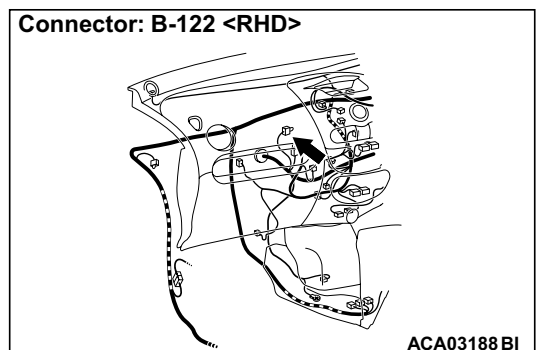
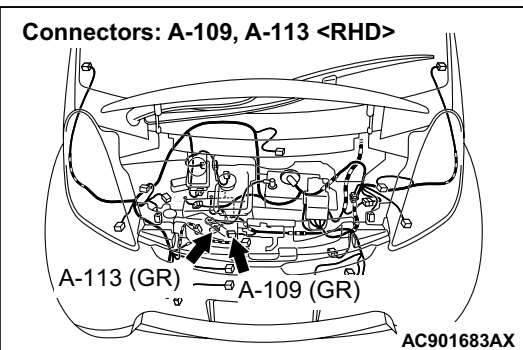
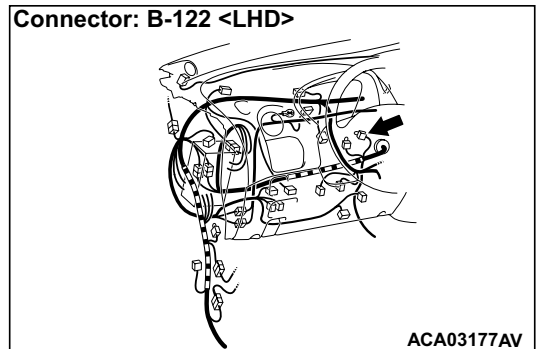
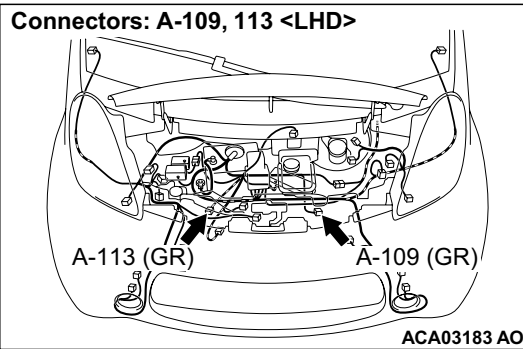

<Correct>

**Connector: C-101, C-115**  
Rear floor lower part

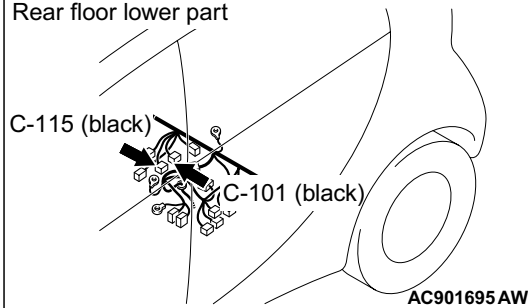

**Connectors: G-21, G-23**

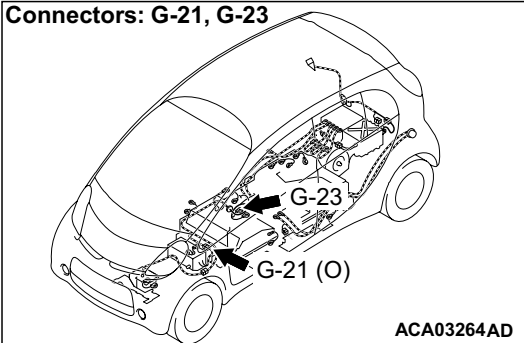

### Diagnosis code set conditions

This code is set when the outlet temperature of the heater does not raise to a temperature higher than the inlet temperature by 3°C or more for 30 seconds or more.

### PROBABLE CAUSES

- Insufficient volume of water heater fluid
- Malfunction of high-voltage fuse No. 3
- Poor connection of high-voltage fuse No. 3
- Malfunction of heater water pump assembly
- Malfunction of EV water PTC heater
- Damaged harness wires and connectors
- Malfunction of heater control unit

### DIAGNOSIS PROCEDURE

#### STEP 1. Check the water heater fluid.

Refer to .

##### Q: Is the water heater fluid volume correct?

**YES** : Go to Step 2.

**NO** : Check the water heater fluid level, and add if necessary.

#### STEP 2. Check the water heater fluid flow.

Drive the heater in READY status and visually check the flow of the water fluid volume in the heater condenser tank.

##### Q: Is the water heater fluid confirmed?

**YES** : Go to Step 8.

**NO** <No heater water pump assembly running noise can be heard> : Go to Step 3.

**NO** <A heater water pump assembly running noise can be heard, but the water heater fluid cannot be confirmed> : Replace the heater water pump assembly.

#### STEP 3. Connector check: A-109 heater water pump assembly connector

##### Q: Is the check result normal?

**YES** : Go to Step 4.

**NO** : Repair the damaged connector.

#### STEP 4. Measure the resistance at A-109 heater water pump assembly connector.

- (1) Disconnect the connector, and measure at the wiring harness side.
- (2) Resistance between terminal No. 2 and body earth

**OK: Continuity exists (2 Ω or less).**

##### Q: Is the check result normal?

**YES** : Go to Step 7.

**NO** : Go to Step 5.

#### STEP 5. Connector check: B-122 grounding connector

##### Q: Is the check result normal?

**YES** : Go to Step 6.

**NO** : Repair the damaged connector.

#### STEP 6. Check the wiring harness between A-109 heater water pump assembly connector terminal No. 2 and B-122 grounding connector terminal No. 5.

- Check the earth wires for open circuit.

##### Q: Is the check result normal?

**YES** : Intermittent malfunction. (Refer to GROUP 00 – How to Use Troubleshooting/ Inspection Service Points, How to Cope with Intermittent Malfunctions .)

**NO** : Repair the wiring harness.

#### STEP 7. Check the heater water pump assembly.

Refer to .

##### Q: Is the check result normal?

**YES** : Intermittent malfunction. (Refer to GROUP 00 – How to Use Troubleshooting/ Inspection Service Points, How to Cope with Intermittent Malfunctions .)

**NO** : Replace the heater water pump assembly.



**STEP 8. M.U.T.-III actuator test, service data**

Check the results of the actuator test with the service data.

**Actuator test**

- Item 1: ELC.water heater test mode

**Data list**

- Item 7: ELC.water heater test status

*NOTE: Because actuator test "item1: ELC. water heater test mode" checks variations in the current, turn OFF other electric equipment before the test.*

**Q: Is the check result normal?**

- YES** : Go to Step 9.  
**NO** : Go to Step 14.

**STEP 9. M.U.T.-III data list**

Check that the following service data display contents are normal.

- Item 10: ELC.water heater inlet sensor
- Item 11: ELC.water heater outlet sensor

**Q: Is the check result normal?**

- YES** : Go to Step 18.  
**NO** : Go to Step 10.

**STEP 10. Connector check: A-113 EV water PTC heater connector****Q: Is the check result normal?**

- YES** : Go to Step 11.  
**NO** : Repair the damaged connector.

**STEP 11. Check the heater outlet water temperature sensor/heater inlet water temperature sensor.**

Refer to .

**Q: Is the check result normal?**

- YES** : Go to Step 12.  
**NO** : Replace the heater.

**STEP 12. Connector check: C-101 A/C control unit connector****Q: Is the check result normal?**

**YES** : Go to Step 13.

**NO** : Repair the damaged connector.

**STEP 13. Check the wiring harness between A-113 EV water PTC heater connector terminal No. 6, 7, 8 and C-101 A/C control unit connector terminal No. 19, 17, 18.**

- Check the power supply and the wiring harness wires to the sensor for damage.

*NOTE: Before checking the wiring harness, check the intermediate connector B-01 and repair it if necessary.*

**Q: Is the check result normal?**

- YES** : Go to Step 18.  
**NO** : Repair the wiring harness.

**STEP 14. Connector check: A-113 EV water PTC heater connector****Q: Is the check result normal?**

- YES** : Go to Step 15.  
**NO** : Repair the damaged connector.

**STEP 15. Connector check: C-113 A/C control unit connector****Q: Is the check result normal?**

- YES** : Go to Step 16.  
**NO** : Repair the damaged connector.

**STEP 16. Check the wiring harness between A-113 EV water PTC heater connector terminal No. 1, 2, 3, 4, 5 and C-113 A/C control unit connector terminal No. 25, 33, 34, 35, 36.**

- Check the heater 12V-power supply and the heater drive circuits for open circuit.

*NOTE: Before checking the wiring harness, check the intermediate connector B-01 and repair it if necessary.*

**Q: Is the check result normal?**

- YES** : Go to Step 17.  
**NO** : Repair the wiring harness.

<Correct>

**STEP 17. Check the high-voltage connector and wiring harness.**

**⚠ DANGER**

***Carry out the check on the high-voltage circuit while reading carefully the precautions on handling a high-voltage vehicle. Refer to .***

**⚠ DANGER**

***Wear the specified protection equipment during the check.***

1. Shut down the high voltage. (Refer to GROUP 00 – Precautions before Service - Precautions on handling high-voltage vehicle .)
2. G-21 Check the heater connector.
3. G-23 Check the high-voltage fuse No. 3 connecting bolt for looseness.
4. Visually check and check the continuity of the high-voltage fuse No. 3.
5. Visually check the following high-voltage wiring harnesses for damage.
  - High-voltage wiring harness on main battery side
  - High-voltage harness heater side

**Q: Is the check result normal?**

**YES :** Go to Step 18.

**NO <Malfunction of high-voltage fuse No. 3> :**  
Replace the high-voltage fuse No. 3.

**NO <Malfunction of wiring harness on heater side> :**  
Replace the heater.

**NO <Malfunction of wiring harness on main battery side> :** Replace the main battery.

**STEP 18. Check whether the diagnosis code is reset.**

**Q: Is the diagnosis code set?**

**YES :** Go to Step 19.

**NO :** Intermittent malfunction. (Refer to GROUP 00 – How to Use Troubleshooting/ Inspection Service Points, How to Cope with Intermittent Malfunctions .)

**STEP 19. After replacing the A/C control unit, check again if the diagnosis code is set.**

**Q: Is the diagnosis code set?**

**YES :** Replace the heater.

**NO :** This diagnosis is complete.

<Correct>



Code No. B1109 Electric water heater system abnormal stop 2

Water heater system circuit

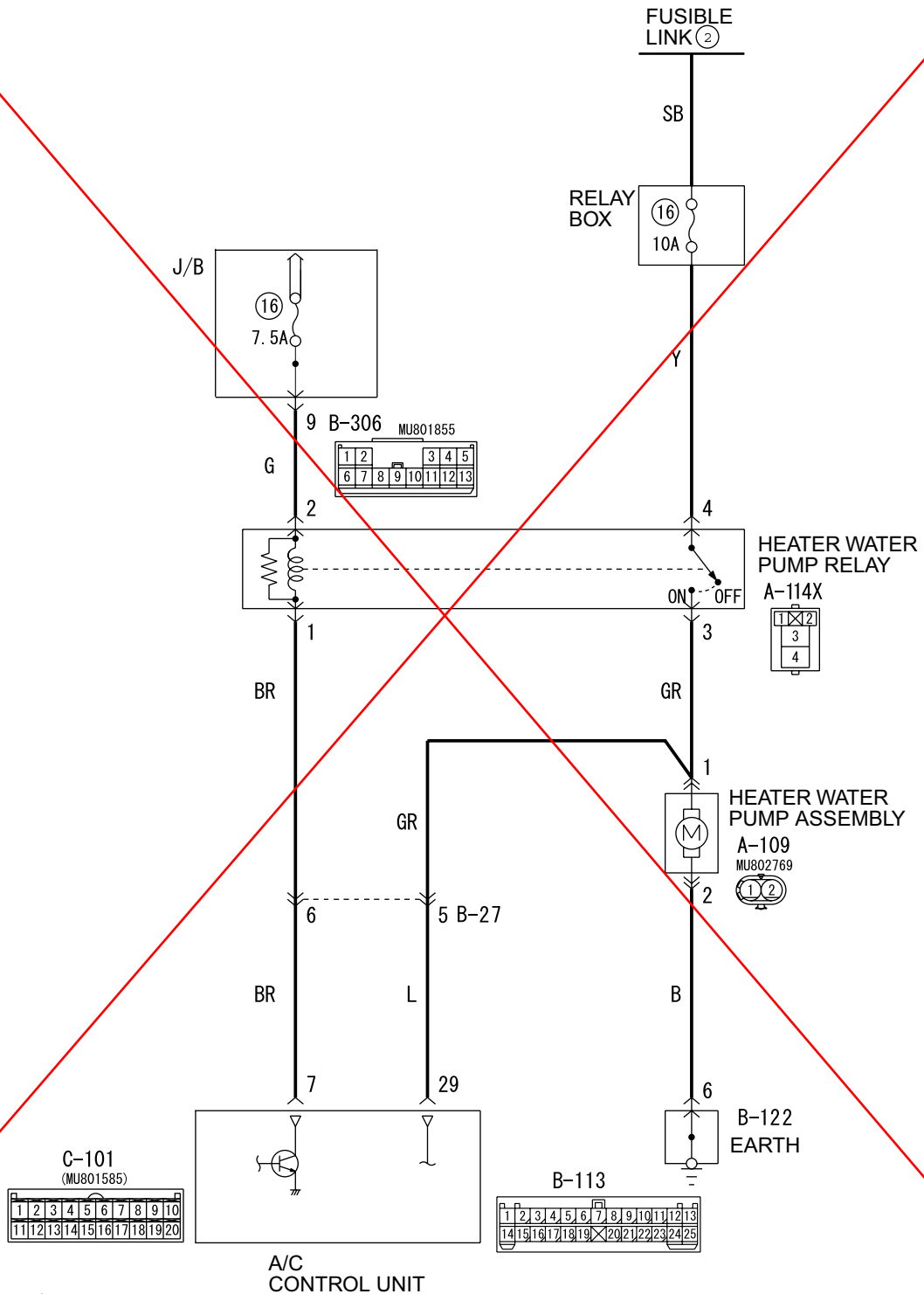

Wire colour code  
 B : Black LG : Light green G : Green L : Blue W : White Y : Yellow SB : Sky blue  
 BR : Brown O : Orange GR : Grey R : Red P : Pink V : Violet PU : Purple SI : Silver

ACA03321

<Incorrect>

Inset the attached sheet 14

A/C control circuit

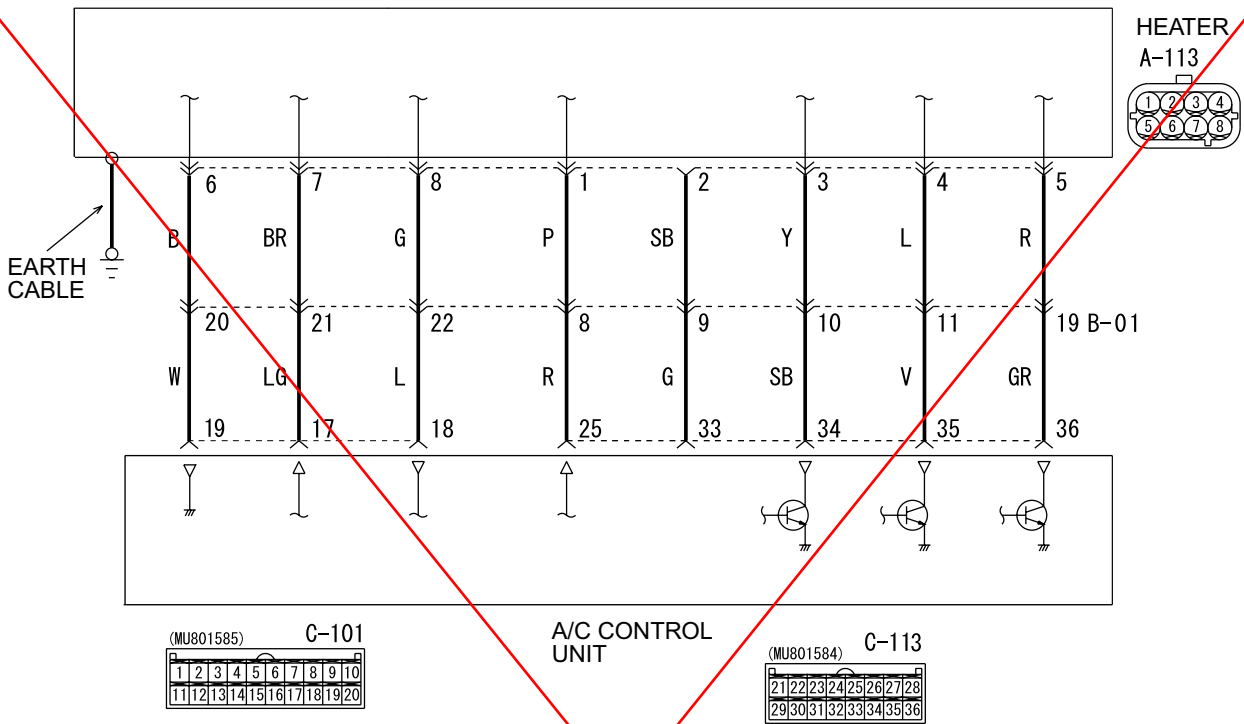

ACA04036

Wire colour code

B : Black LG : Light green G : Green L : Blue W : White Y : Yellow SB : Sky blue  
 BR : Brown O : Orange GR : Grey R : Red P : Pink V : Violet PU : Purple SI : Silver

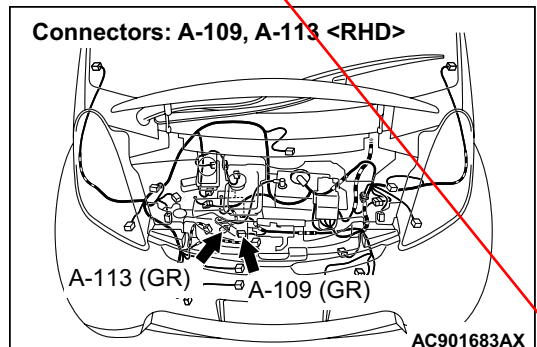
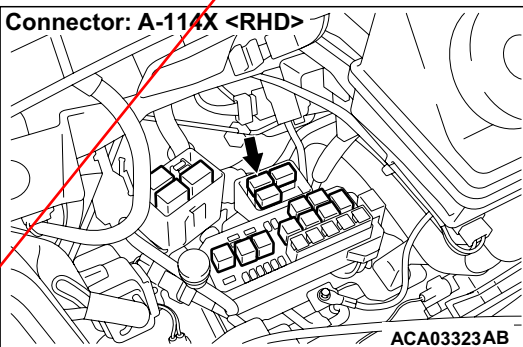
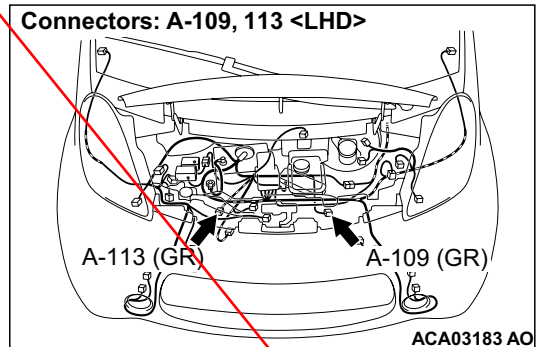
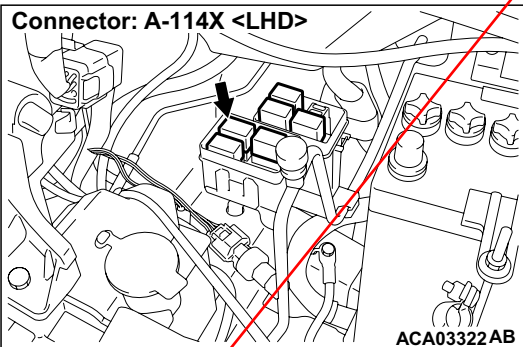

<Incorrect>

Inset the attached sheet 14

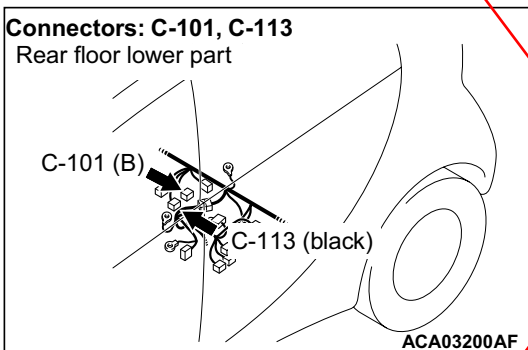
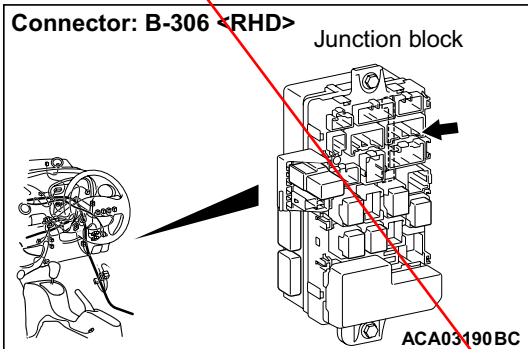
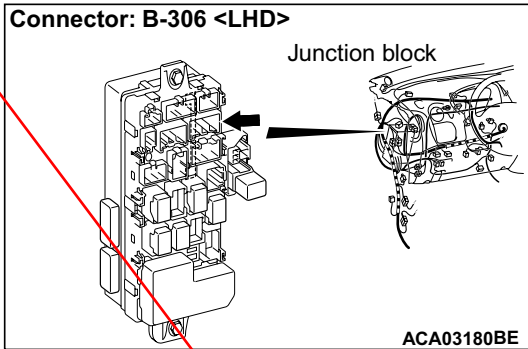

**DIAGNOSIS CODE SET CONDITIONS**

This code is set when the outlet temperature of the heater is higher than the inlet temperature by 40°C or more for 30 seconds or more after 30 seconds has passed since the start of the heater control.

**PROBABLE CAUSES**

- Insufficient volume of water heater fluid
- Malfunction of heater water pump assembly
- Malfunction of heater
- Damaged harness wires and connectors
- Malfunction of A/C control unit

**DIAGNOSIS PROCEDURE**

**STEP 1. Check the water heater fluid volume.**

**Q: Is the water heater fluid volume correct?**  
**YES :** Go to Step 2.  
**NO :** Make the water heater fluid volume correct.

**STEP 2. Check the heater water pump assembly.**  
 Drive the heater in READY status and visually check the flow of the water fluid volume in the heater condenser tank.

**Q: Is the heater water pump assembly in good condition?**  
**YES :** Go to Step 3.  
**NO :** Replace the heater water pump assembly.

**STEP 3. M.U.T.-III data list**

Check that the following service data display contents are normal.

- Item 8: Electric water pump output
- Item 10: Electric water heater inlet water temperature sensor
- Item 11: Electric water heater outlet water temperature sensor

**Q: Is the check result normal?**  
**YES :** Go to Step 4.  
**NO :** Go to Step 19.

**STEP 4. Connector check: A-113 heater connector**

**Q: Is the check result normal?**  
**YES :** Go to Step 5.  
**NO :** Repair the damaged connector.

**STEP 5. Check the heater outlet water temperature sensor/heater inlet water temperature sensor.**

Refer to .

**Q: Is the check result normal?**  
**YES :** Go to Step 6.  
**NO :** Replace the heater.

**STEP 6. Connector check: A-114X heater water pump relay connector**

**Q: Is the check result normal?**  
**YES :** Go to Step 7.  
**NO :** Repair the damaged connector.

**STEP 7. Check the heater water pump relay.**

Refer to .

**Q: Is the heater water pump relay in good condition?**  
**YES :** Go to Step 8.  
**NO :** Replace the heater water pump relay.

**STEP 8. Measure the voltage at A-114X heater water pump relay connector.**  
 (1) Disconnect the connector, and measure at the

wiring harness side.

(2) Voltage between terminal 4 and body earth

**OK: Battery voltage**

**Q: Is the check result normal?**

**YES :** Go to Step 10.

**NO :** Go to Step 9.

**STEP 9. Check the wiring harness between A-114X heater water pump relay connector terminal No. 4 and the fusible link (2).**

- Check the power supply line for open circuit.

**Q: Is the check result normal?**

**YES :** Intermittent malfunction. Refer to GROUP 00 – How to Use Troubleshooting/ Inspection Service Points, – How to Cope with Intermittent Malfunctions .)

**NO :** Repair the wiring harness.

**STEP 10. Measure the resistance at A-109 heater water pump assembly connector.**

- (1) Disconnect the connector, and measure at the wiring harness side.
- (2) Resistance between terminal No. 2 and body earth

**OK: Continuity exists (2 Ω or less)**

**Q: Is the check result normal?**

**YES :** Go to Step 12.

**NO :** Go to Step 11.

**STEP 11. Check the wiring harness between A-109 heater water pump assembly connector terminal No. 2 and the body earth.**

- Check the earth wires for open circuit.

*NOTE: Before checking the wiring harness, check the earth connector B-122 and repair it if necessary.*

**Q: Is the check result normal?**

**YES :** Intermittent malfunction. Refer to GROUP 00 – How to Use Troubleshooting/ Inspection Service Points, – How to Cope with Intermittent Malfunctions .)

**NO :** Repair the wiring harness.

**STEP 12. Check the wiring harness between A-114X heater water pump relay connector terminal No. 2 and B-306 junction block connector terminal No. 9.**

- Check the power supply line for open circuit.

**Q: Is the check result normal?**

**YES :** Go to Step 13.

**NO :** Repair the wiring harness.

**STEP 13. Connector check: C-101, C-113 compressor & heater controller connectors**

**Q: Is the check result normal?**

**YES :** Go to Step 14.

**NO :** Repair the damaged connector.

**STEP 14. Check the wiring harness between A-114X heater water pump relay connector terminal No. 1 and C-101 compressor & heater controller connector terminal No. 7.**

- Check the power supply line for open circuit.

*NOTE: Before checking the wiring harness, check the intermediate connector B-27 and repair it if necessary.*

**Q: Is the check result normal?**

**YES :** Go to Step 15.

**NO :** Repair the wiring harness.

**STEP 15. Check the wiring harness between A-114X heater water pump relay connector terminal No. 3 and A-109 heater water pump assembly connector terminal No. 1.**

- Check the power supply line for open circuit.

**Q: Is the check result normal?**

**YES :** Go to Step 16.

**NO :** Repair the wiring harness.

**STEP 16. Check the wiring harness between A-109 heater water pump assembly connector terminal No. 1 and C-113 A/C control unit connector terminal No. 29.**

- Check the input line for open circuit.

*NOTE: Before checking the wiring harness, check the intermediate connector B-27 and repair it if necessary.*

**Q: Is the check result normal?**

**YES :** Go to Step 17.

**NO :** Repair the wiring harness.

**STEP 17. Check the wiring harness between A-113 heater connector terminal connector terminal No. 6, 7, 8, 1, 3, 4, 5 and C-101 compressor & heater controller connector terminal No. 19, 17, 18, C-113 A/C control unit connector terminal No. 25, 34, 35, 36.**

- Check the input line for open circuit.

*NOTE: Before checking the wiring harness, check the intermediate connector B-01 and repair it if necessary.*

**Q: Is the check result normal?**

<Incorrect>

...E55-501A(12A P002A)

Inset the attached sheet 14

YES : Go to Step 18.  
NO : Repair the wiring harness.

---

**STEP 18. Check whether the diagnosis code is reset.**

**Q: Is the diagnosis code set?**  
YES : Go to Step 19.  
NO : Intermittent malfunction. Refer to GROUP 00 – How to Use Troubleshooting/ Inspection Service Points, – How to Cope with Intermittent Malfunctions .)

**STEP 19. After replacing the compressor & heater controller, check again if the diagnosis code is set.**

**Q: Is the diagnosis code set?**  
YES : Replace the heater.  
NO : This diagnosis is complete.

<Incorrect>

Inset the attached sheet 14

Code No. B1109 Electric water heater fail 2

Heater water pump circuit

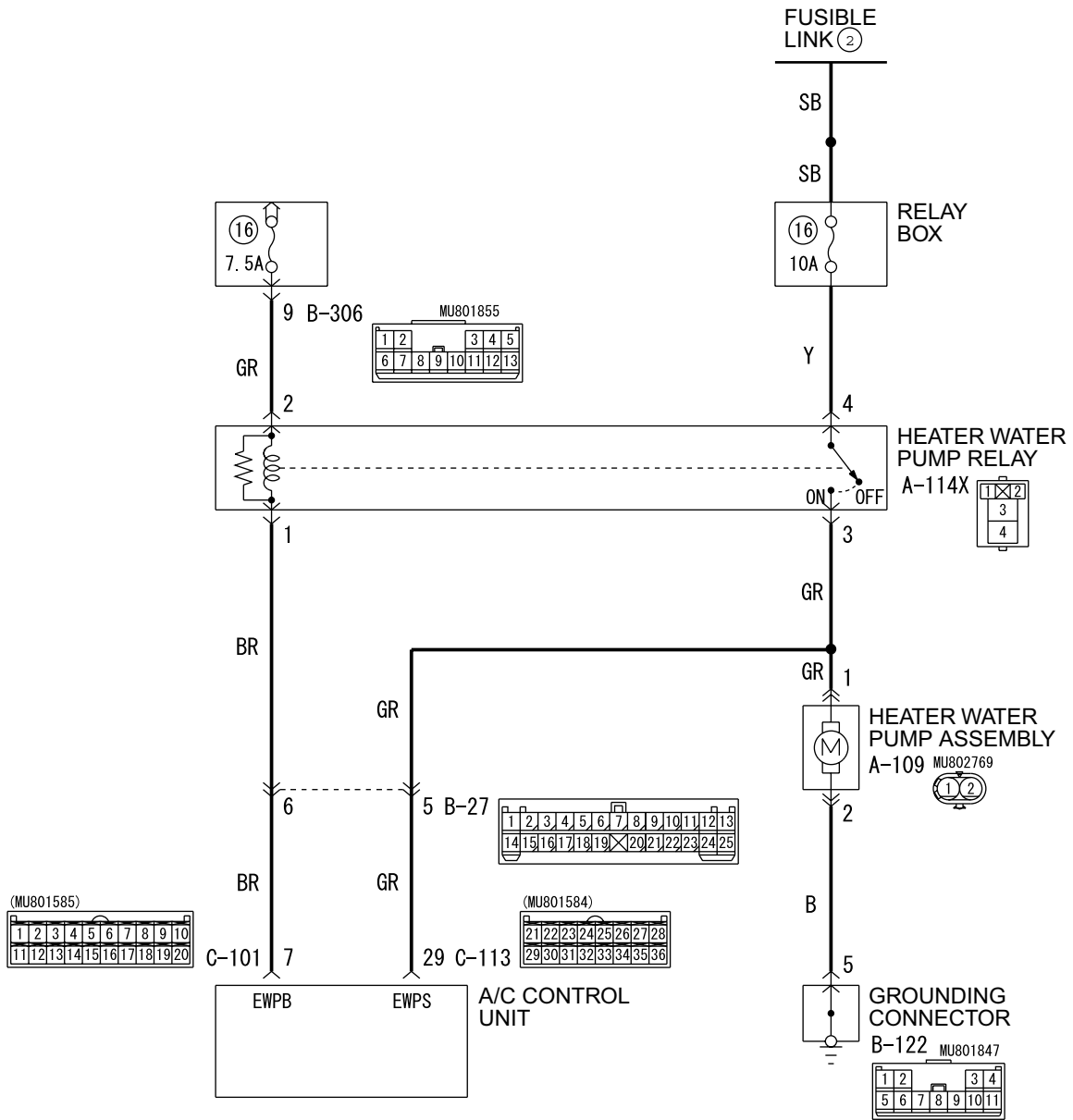

ACC00319  
WDT55M007A

<Correct>

A/C Control Circuit

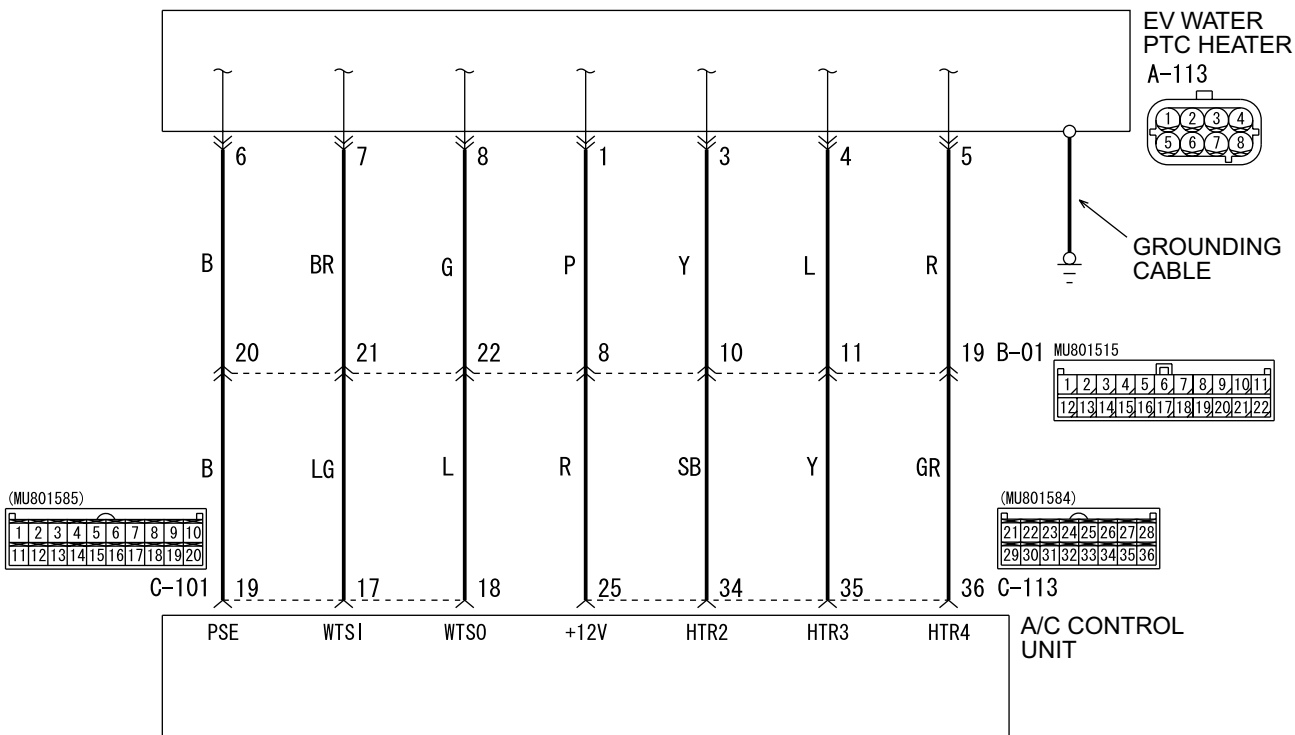

ACC00326  
WDT55M008A

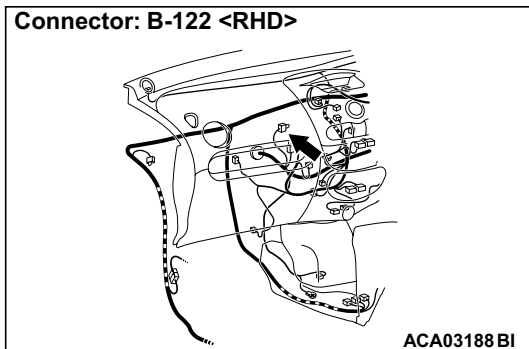
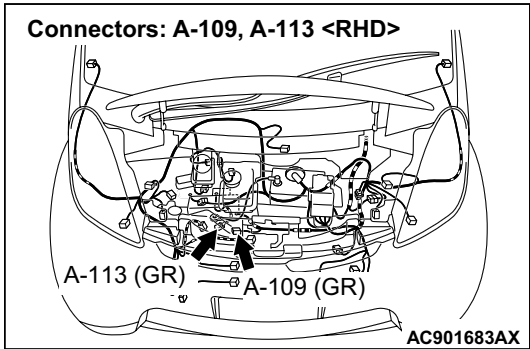
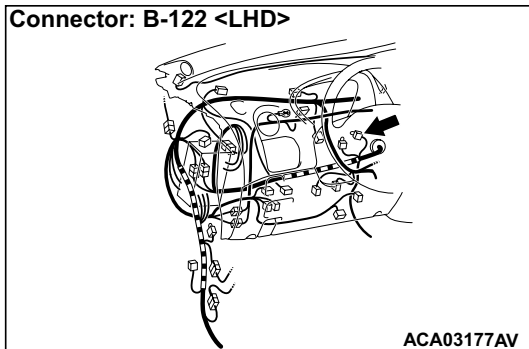
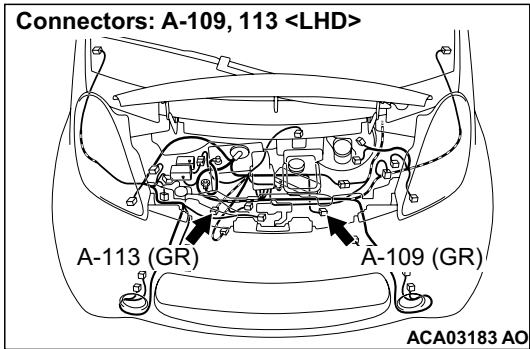

<Correct>



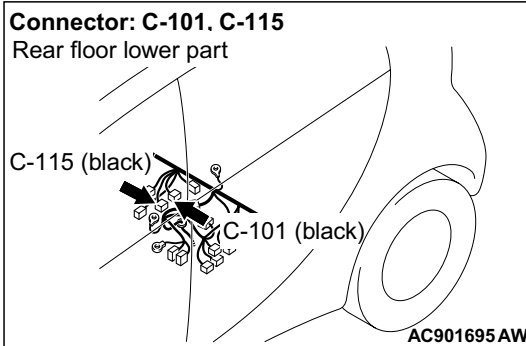

### Diagnosis code set conditions

This code is set when the outlet temperature of the heater is higher than the inlet temperature by 40°C or more for 30 seconds or more after 30 seconds has passed since the start of the heater control.

### PROBABLE CAUSES

- Insufficient volume of water heater fluid
- Malfunction of heater water pump assembly
- Malfunction of EV water PTC heater
- Damaged harness wires and connectors
- Malfunction of A/C control unit

### DIAGNOSIS PROCEDURE

#### STEP 1. Check the water heater fluid.

Refer to .

#### Q: Is the water heater fluid volume correct?

**YES** : Go to Step 2.

**NO** : Check the water heater fluid level, and add if necessary.

#### STEP 2. Check the water heater fluid flow.

Drive the heater in READY status and visually check the flow of the water fluid volume in the heater condenser tank.

#### Q: Is the water heater fluid confirmed?

**YES** : Go to Step 8.

**NO <No heater water pump assembly running noise can be heard>** : Go to Step 3.

**NO <A heater water pump assembly running noise can be heard, but the water heater fluid cannot be confirmed>** : Replace the heater water pump assembly.

#### STEP 3. Connector check: A-109 heater water pump assembly connector

#### Q: Is the check result normal?

**YES** : Go to Step 5.

**NO** : Repair the damaged connector.

#### STEP 4. Measure the resistance at A-109 heater water pump assembly connector.

- (1) Disconnect the connector, and measure at the wiring harness side.
- (2) Resistance between terminal No. 2 and body earth

**OK: Continuity exists (2 Ω or less).**

#### Q: Is the check result normal?

**YES** : Go to Step 7.

**NO** : Go to Step 5.

#### STEP 5. Connector check: B-122 grounding connector

#### Q: Is the check result normal?

**YES** : Go to Step 6.

**NO** : Repair the damaged connector.

#### STEP 6. Check the wiring harness between A-109 heater water pump assembly connector terminal No. 2 and B-122 grounding connector terminal No. 5.

- Check the earth wires for open circuit.

#### Q: Is the check result normal?

**YES** : Intermittent malfunction. (Refer to GROUP 00 – How to Use Troubleshooting/ Inspection Service Points, How to Cope with Intermittent Malfunctions .)

**NO** : Repair the wiring harness.

#### STEP 7. Check the heater water pump assembly.

Refer to .

#### Q: Is the check result normal?

**YES** : Intermittent malfunction. (Refer to GROUP 00 – How to Use Troubleshooting/ Inspection Service Points, How to Cope with Intermittent Malfunctions .)

**NO** : Replace the heater water pump assembly.

#### STEP 8. M.U.T.-III data list

Check that the following service data display contents are normal.

#### Actuator test

- Item 1: ELC.water heater test mode

#### Data list

- Item 7: ELC.water heater test status

#### Q: Is the check result normal?

**YES** : Go to Step 13.

**NO** : Go to Step 9.

<Correct>



---

**STEP 9. Connector check: A-113 EV water PTC heater connector**

**Q: Is the check result normal?**  
**YES :** Go to Step 10.  
**NO :** Repair the damaged connector.

---

**STEP 10. Check the heater outlet water temperature sensor/heater inlet water temperature sensor.**

Refer to .

**Q: Is the check result normal?**  
**YES :** Go to Step 11.  
**NO :** Replace the heater.

---

**STEP 11. Connector check: C-101 A/C control unit controller connector**

**Q: Is the check result normal?**  
**YES :** Go to Step 12.  
**NO :** Repair the damaged connector.

---

**STEP 12. Check the wiring harness between A-113 EV water PTC heater connector terminal No. 6, 7, 8 and C-101 A/C control unit controller connector terminal No. 19, 17, 18.**

- Check the wiring harness for damage.

*NOTE: Before checking the wiring harness, check the intermediate connector B-01 and repair it if necessary.*

**Q: Is the check result normal?**  
**YES :** Go to Step 16.  
**NO :** Repair the wiring harness.

---

**STEP 13. Connector check: A-113 EV water PTC heater connector**

**Q: Is the check result normal?**

**YES :** Go to Step 14.  
**NO :** Repair the damaged connector.

---

**STEP 14. Connector check: C-113 A/C control unit connector**

**Q: Is the check result normal?**  
**YES :** Go to Step 15.  
**NO :** Repair the damaged connector.

---

**STEP 15. Check the wiring harness between A-113 EV water PTC heater connector terminal No. 1, 2, 3, 4, 5 and C-113 A/C control unit connector terminal No. 25, 33, 34, 35, 36.**

- Check the heater drive circuit for short to earth.

*NOTE: Before checking the wiring harness, check the intermediate connector B-01 and repair it if necessary.*

**Q: Is the check result normal?**  
**YES :** Go to Step 16.  
**NO :** Repair the wiring harness.

---

**STEP 16. Check whether the diagnosis code is reset.**

**Q: Is the diagnosis code set?**  
**YES :** Go to Step 17.  
**NO :** Intermittent malfunction. (Refer to GROUP 00 – How to Use Troubleshooting/ Inspection Service Points, How to Cope with Intermittent Malfunctions .)

---

**STEP 17. After replacing the A/C control unit, check again if the diagnosis code is set.**

**Q: Is the diagnosis code set?**  
**YES :** Replace the heater.  
**NO :** This diagnosis is complete.

<Correct>

Code No. B1110 Electric water heater system abnormal stop 3

Water heater system circuit

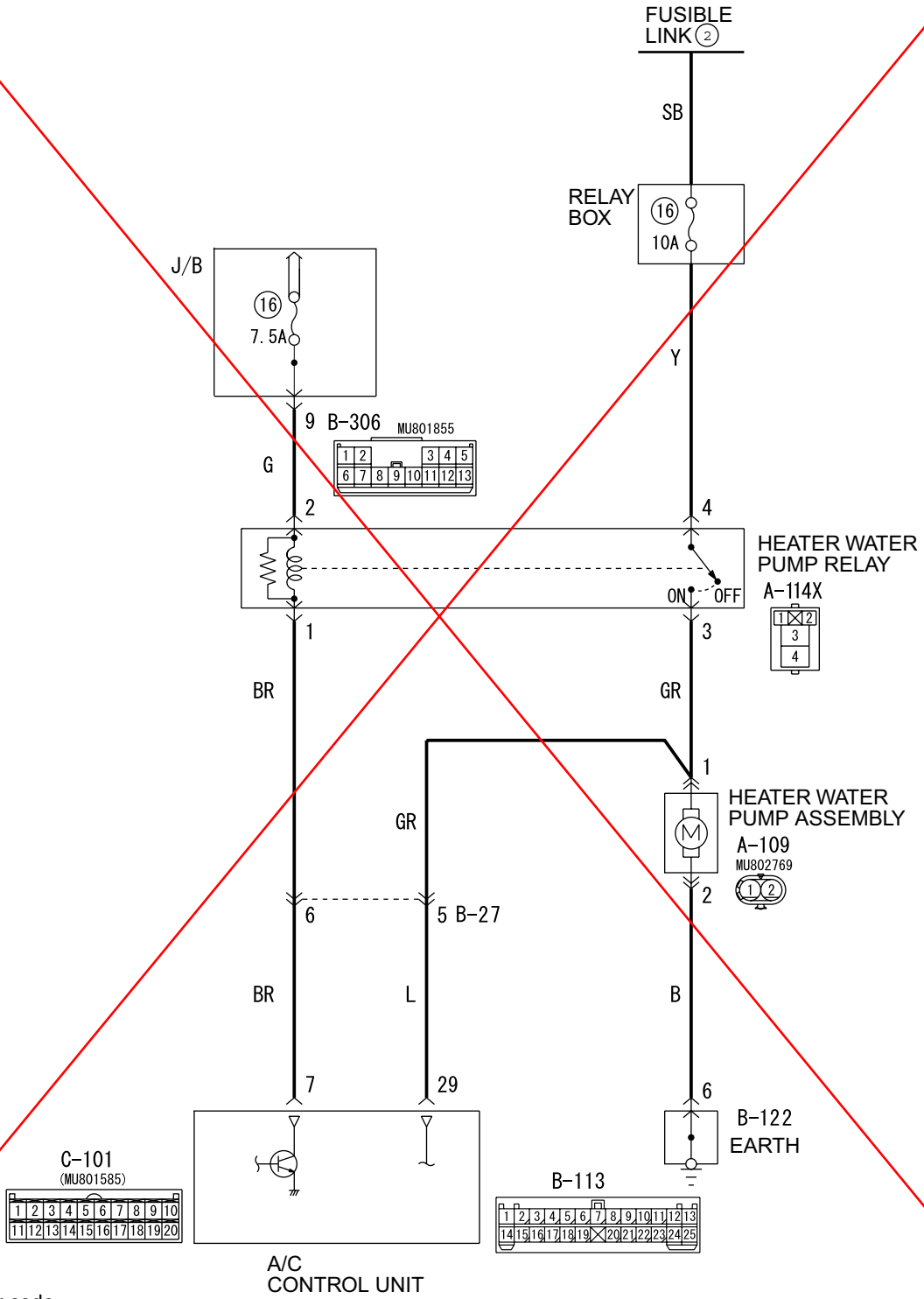

Wire colour code  
 B : Black    LG : Light green    G : Green    L : Blue    W : White    Y : Yellow    SB : Sky blue  
 BR : Brown    O : Orange    GR : Grey    R : Red    P : Pink    V : Violet    PU : Purple    SI : Silver

ACA03321

<Incorrect>

Inset the attached sheet 16

A/C control circuit

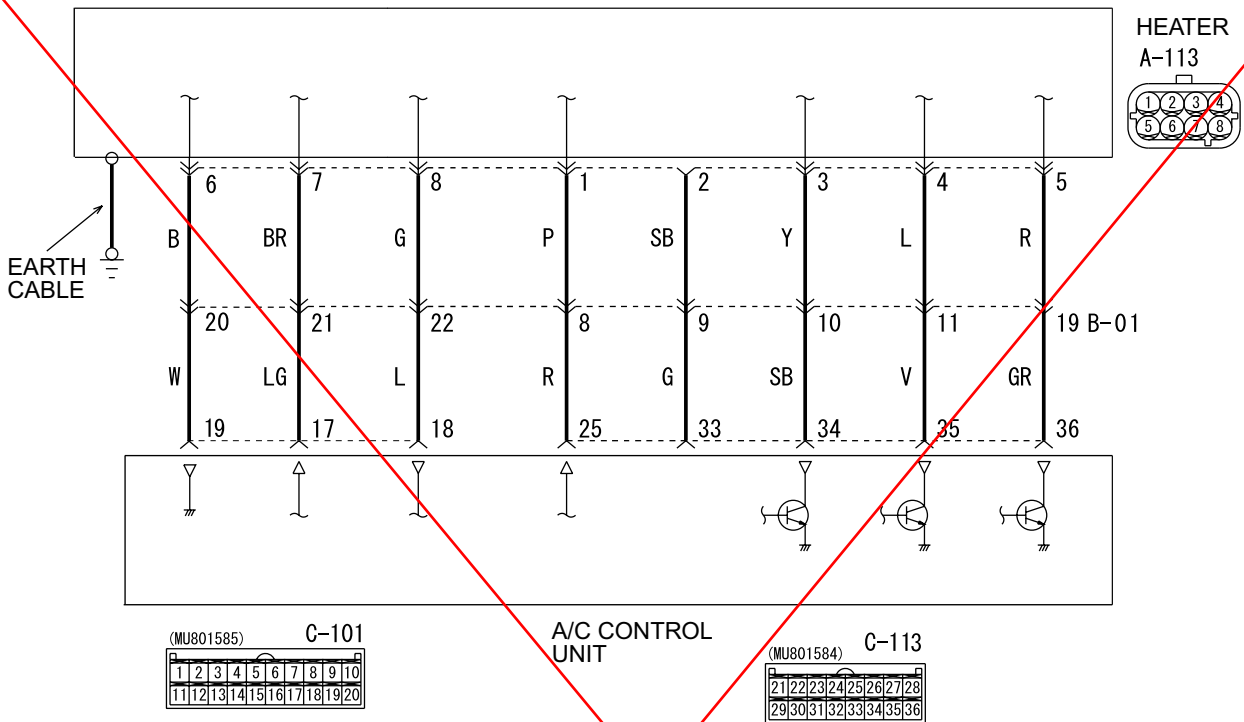

ACA04036

Wire colour code

B : Black LG : Light green G : Green L : Blue W : White Y : Yellow SB : Sky blue  
 BR : Brown O : Orange GR : Grey R : Red P : Pink V : Violet PU : Purple SI : Silver

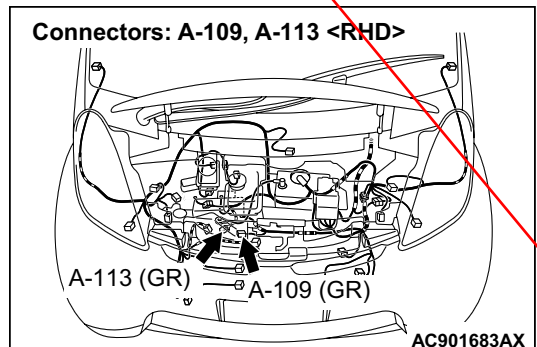
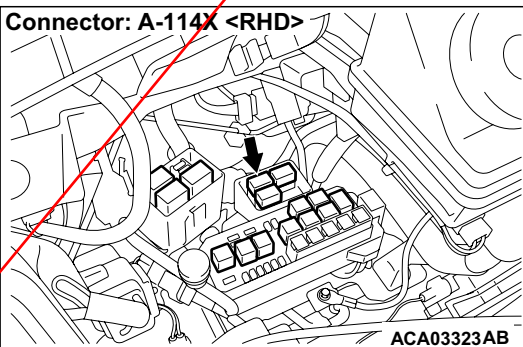
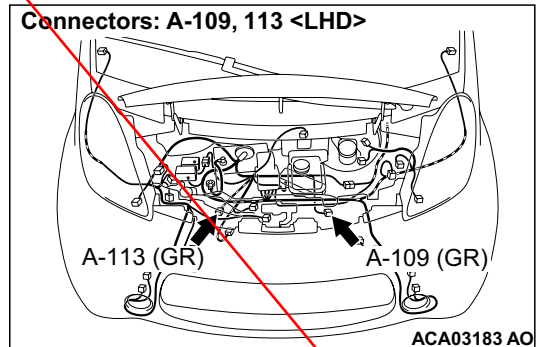
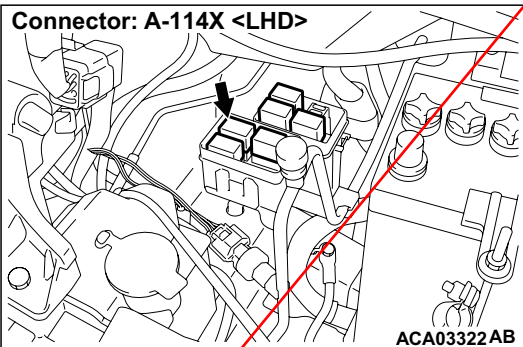

<Incorrect>

Inset the attached sheet 16

Connector: B-18 <LHD>

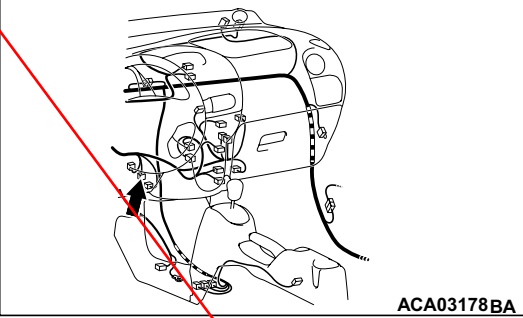

ACA03178BA

Connector: B-18 <RHD>

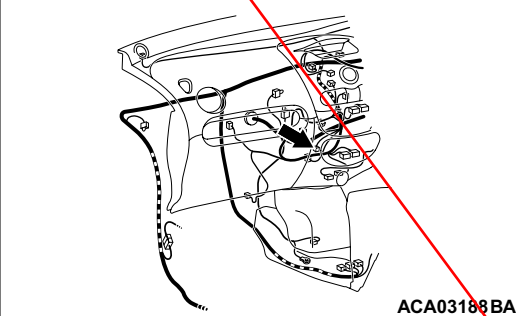

ACA03188BA

Connector: B-306 <LHD>

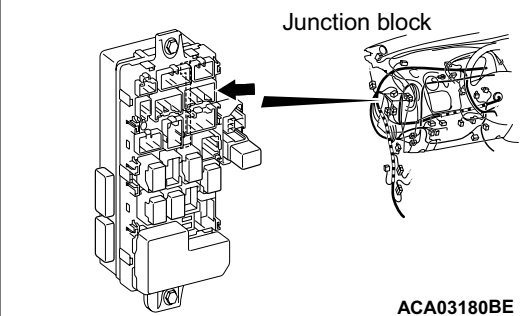

ACA03180BE

Connector: B-306 <RHD>

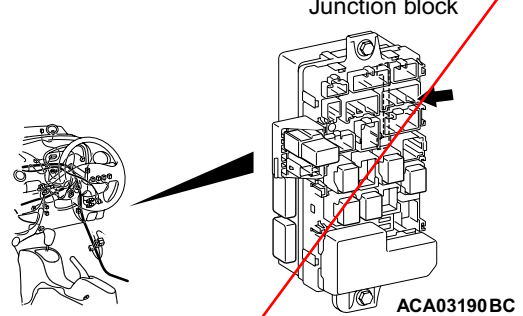

ACA03190BC

Connectors: C-101, C-113  
Rear floor lower part

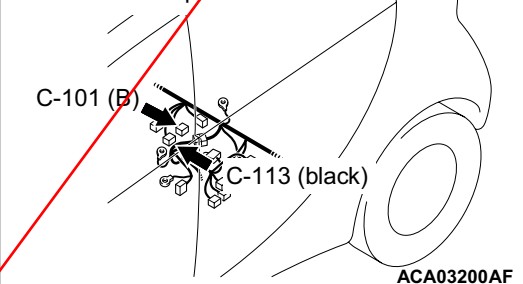

ACA03200AF

**DIAGNOSIS CODE SET CONDITIONS**

This code is set when one of the heater water temperatures at the inlet, outlet, or heater core reaches 100°C or more for 3 seconds or more.

**PROBABLE CAUSES**

- Insufficient volume of water heater fluid
- Malfunction of heater water pump assembly
- Malfunction of heater
- Damaged harness wires and connectors
- Malfunction of A/C control unit

**DIAGNOSIS PROCEDURE**

**STEP 1. Check the water heater fluid volume.**

**Q: Is the water heater fluid volume correct?**

**YES :** Go to Step 2.

**NO :** Make the water heater fluid volume correct.

**STEP 2. Check the heater water pump assembly.**

Drive the heater in READY status and visually check the flow of the water fluid volume in the heater condenser tank.

**Q: Is the heater water pump assembly in good condition?**

**YES :** Go to Step 3.

**NO :** Replace the heater water pump assembly.

**STEP 3. M.U.T.-III data list**

Check that the following service data display contents are normal.

- Item 8: Electric water pump output
- Item 10: Electric water heater inlet water temperature sensor
- Item 11: Electric water heater outlet water temperature sensor

**Q: Is the check result normal?**

**YES :** Go to Step 4.

**NO :** Go to Step 22.

**STEP 4. Connector check: A-113 heater connector**

**Q: Is the check result normal?**

**YES :** Go to Step 5.

**NO :** Repair the damaged connector.

**STEP 5. Check the heater outlet water temperature sensor/heater inlet water temperature sensor.**

Refer to .

**Q: Is the check result normal?**

<Incorrect>

-501A(12AB003A)

28

Inset the attached sheet 16

**YES** : Go to Step 6.  
**NO** : Replace the heater.

---

**STEP 6. Heater controller (A/C-ECU) M.U.T.-III service data**

Check that the following service data display contents are normal.

- Item 24: Coolant temperature sensor

**Q: Is the check result normal?**

**YES** : Go to Step 9.  
**NO** : Go to Step 7.

---

**STEP 7. Connector check: B-18 heater water temperature connector**

**Q: Is the check result normal?**

**YES** : Go to Step 8.  
**NO** : Repair the damaged connector.

---

**STEP 8. Check the heater water temperature sensor.**

Refer to .

**Q: Is the check result normal?**

**YES** : Go to Step 9.  
**NO** : Replace the heater.

---

**STEP 9. Connector check: A-114X heater water pump relay connector**

**Q: Is the check result normal?**

**YES** : Go to Step 10.  
**NO** : Repair the damaged connector.

---

**STEP 10. Check the heater water pump relay.**

Refer to .

**Q: Is the heater water pump relay in good condition?**

**YES** : Go to Step 11.  
**NO** : Replace the heater water pump relay.

---

**STEP 11. Measure the voltage at A-114X heater water pump relay connector.**

(1) Disconnect the connector, and measure at the wiring harness side.

(2) Voltage between terminal 4 and body earth

**OK: Battery voltage**

**Q: Is the check result normal?**

**YES** : Go to Step 13.  
**NO** : Go to Step 12.

---

**STEP 12. Check the wiring harness between A-114X heater water pump relay connector terminal No. 4 and the fusible link (2).**

- Check the power supply line for open circuit.

**Q: Is the check result normal?**

**YES** : Intermittent malfunction. Refer to GROUP 00 – How to Use Troubleshooting/ Inspection Service Points, – How to Cope with Intermittent Malfunctions .)

**NO** : Repair the wiring harness.

---

**STEP 13. Measure the resistance at A-109 heater water pump assembly connector.**

(1) Disconnect the connector, and measure at the wiring harness side.

(2) Resistance between terminal No. 2 and body earth

**OK: Continuity exists (2 Ω or less)**

**Q: Is the check result normal?**

**YES** : Go to Step 15.  
**NO** : Go to Step 14.

---

**STEP 14. Check the wiring harness between A-109 heater water pump assembly connector terminal No. 2 and the body earth.**

- Check the earth wires for open circuit.

*NOTE: Before checking the wiring harness, check the earth connector B-122 and repair it if necessary.*

**Q: Is the check result normal?**

**YES** : Intermittent malfunction. Refer to GROUP 00 – How to Use Troubleshooting/ Inspection Service Points, – How to Cope with Intermittent Malfunctions .)

**NO** : Repair the wiring harness.

---

**STEP 15. Check the wiring harness between A-104X heater water pump relay connector terminal No. 2 and B-306 junction block connector terminal No. 9.**

- Check the power supply line for open circuit.

**Q: Is the check result normal?**

**YES** : Go to Step 16.  
**NO** : Repair the wiring harness.

---

**STEP 16. Connector check: C-101, C-113 compressor & heater controller connectors**

**Q: Is the check result normal?**

**YES** : Go to Step 17.  
**NO** : Repair the damaged connector.

<Incorrect>

**STEP 17. Check the wiring harness between A-114X heater water pump relay connector terminal No. 1 and C-101 A/C control unit connector terminal No. 7.**

- Check the power supply line for open circuit.

*NOTE: Before checking the wiring harness, check the intermediate connector B-27 and repair it if necessary.*

**Q: Is the check result normal?**

**YES :** Go to Step 18.

**NO :** Repair the wiring harness.

**STEP 18. Check the wiring harness between A-114X heater water pump relay connector terminal No. 3 and A-109 heater water pump assembly connector terminal No. 1.**

- Check the power supply line for open circuit.

**Q: Is the check result normal?**

**YES :** Go to Step 19.

**NO :** Repair the wiring harness.

**STEP 19. Check the wiring harness between A-109 heater water pump assembly connector terminal No. 1 and C-113 A/C control unit connector terminal No. 29.**

- Check the input line for open circuit.

*NOTE: Before checking the wiring harness, check the intermediate connector B-27 and repair it if necessary.*

**Q: Is the check result normal?**

**YES :** Go to Step 20.

**NO :** Repair the wiring harness.

**STEP 20. Connector check: A-113 heater connector**

**Q: Is the check result normal?**

**YES :** Go to Step 21.

**NO :** Repair the damaged connector.

**STEP 21. Check the wiring harness between A-113 heater connector terminal connector terminal No. 6, 7, 8, 1, 3, 4, 5 and C-101 A/C control unit connector terminal No. 19, 17, 18, C-113 compressor & heater controller connector terminal No. 25, 34, 35, 36.**

- Check the input line for open circuit.

*NOTE: Before checking the wiring harness, check the intermediate connector B-01 and repair it if necessary.*

**Q: Is the check result normal?**

**YES :** Go to Step 22.

**NO :** Repair the wiring harness.

**STEP 22. Check whether the diagnosis code is reset.**

**Q: Is the diagnosis code set?**

**YES :** Go to Step 23.

**NO :** Intermittent malfunction. Refer to GROUP 00 – How to Use Troubleshooting/ Inspection Service Points, – How to Cope with Intermittent Malfunctions .)

**STEP 23. After replacing the compressor & heater controller, check again if the diagnosis code is set.**

**Q: Is the diagnosis code set?**

**YES :** Replace the heater.

**NO :** This diagnosis is complete.

<Incorrect>

Inset the attached sheet 16









Connectors: A-109, 113 <LHD>

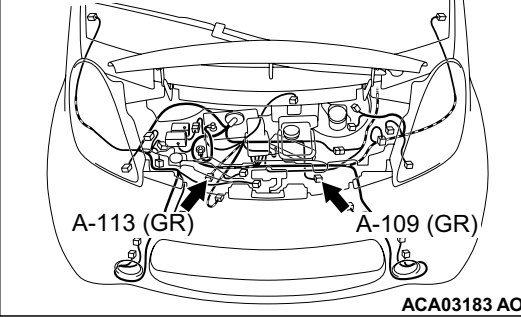

Connectors: A-109, A-113 <RHD>

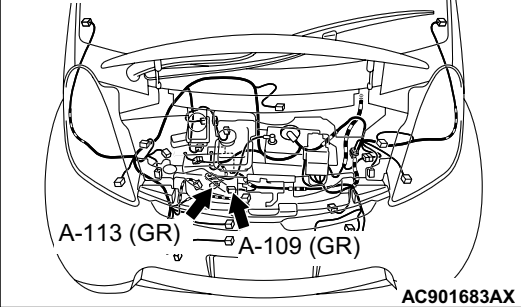

Connectors: B-09, B-16, B-18 <LHD>

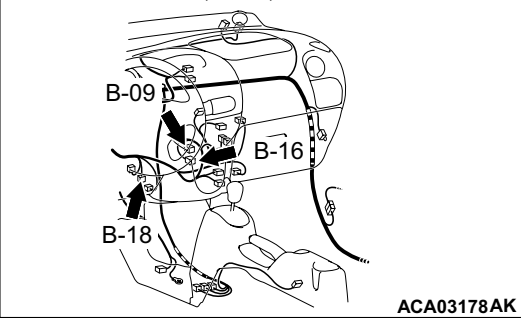

Connectors: B-09, B-16, B-18, B-122 <RHD>

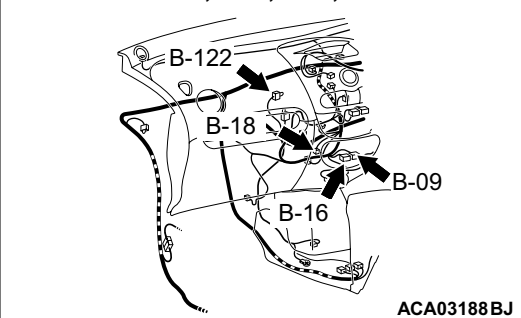

Connector: B-122 <LHD>

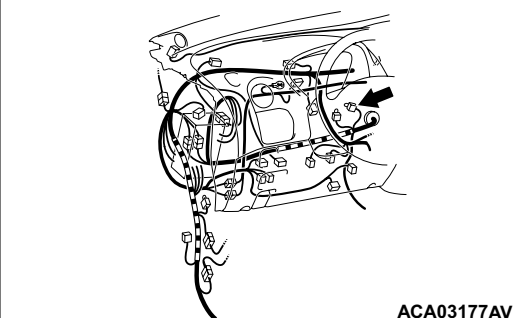

Connector: C-101, C-115

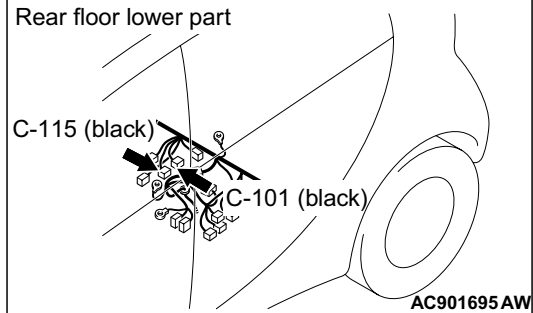

### Diagnosis code set conditions

This code is set when one of the heater water temperatures at the inlet, outlet, or heater core reaches 100°C or more for 3 seconds or more.

### PROBABLE CAUSES

- Insufficient volume of water heater fluid
- Malfunction of heater water pump assembly
- Malfunction of EV water PTC heater
- Damaged harness wires and connectors
- Malfunction of A/C control unit

### DIAGNOSIS PROCEDURE

#### STEP 1. Check the water heater fluid volume.

Refer to .

**Q: Is the water heater fluid volume correct?**

**YES :** Go to Step 2.

**NO :** Check the water heater fluid level, and add if necessary.

#### STEP 2. Check the water heater fluid flow.

Drive the heater in READY status and visually check the flow of the water fluid volume in the heater condenser tank.

**Q: Is the water heater fluid confirmed?**

**YES :** Go to Step 8.

**NO <No heater water pump assembly running noise can be heard> :** Go to Step 3.

**NO <A heater water pump assembly running noise can be heard, but the water heater fluid cannot be confirmed> :** Replace the heater water pump assembly.

#### STEP 3. Connector check: A-109 heater water pump assembly connector

**Q: Is the check result normal?**

**YES :** Go to Step 4.

**NO :** Repair the damaged connector.

<Correct>

**STEP 4. Measure the resistance at A-109 heater water pump assembly connector.**

- (1) Disconnect the connector, and measure at the wiring harness side.
- (2) Resistance between terminal No. 2 and body earth

**OK: Continuity exists (2 Ω or less).**

**Q: Is the check result normal?**

- YES :** Go to Step 6.  
**NO :** Go to Step 5.

**STEP 5. Check the heater water pump assembly.**

Refer to .

**Q: Is the check result normal?**

- YES :** Intermittent malfunction. (Refer to GROUP 00 – How to Use Troubleshooting/ Inspection Service Points, How to Cope with Intermittent Malfunctions .)  
**NO :** Replace the heater water pump assembly.

**STEP 6. Connector check: B-122 grounding connector**

**Q: Is the check result normal?**

- YES :** Go to Step 7.  
**NO :** Repair the damaged connector.

**STEP 7. Check the wiring harness between A-109 heater water pump assembly connector terminal No. 2 and B-122 grounding connector terminal No. 5.**

- Check the earth wires for open circuit.

**Q: Is the check result normal?**

- YES :** Intermittent malfunction. (Refer to GROUP 00 – How to Use Troubleshooting/ Inspection Service Points, How to Cope with Intermittent Malfunctions .)  
**NO :** Repair the wiring harness.

**STEP 8. M.U.T.-III data list**

Check that the following service data display contents are normal.

**Actuator test**

- Item 1: ELC.water heater test mode

**Data list**

- Item 7: ELC.water heater test status

**Q: Is the check result normal?**

- YES :** Go to Step 13.  
**NO :** Go to Step 9.

**STEP 9. Connector check: A-113 EV water PTC heater connector**

**Q: Is the check result normal?**

- YES :** Go to Step 10.  
**NO :** Repair the damaged connector.

**STEP 10. Check the heater outlet water temperature sensor/heater inlet water temperature sensor.**

Refer to .

**Q: Is the check result normal?**

- YES :** Go to Step 11.  
**NO :** Replace the heater.

**STEP 11. Connector check: C-101 A/C control unit controller connector**

**Q: Is the check result normal?**

- YES :** Go to Step 12.  
**NO :** Repair the damaged connector.

**STEP 12. Check the wiring harness between A-113 EV water PTC heater connector terminal No. 6, 7, 8 and C-101 A/C control unit connector terminal No. 19, 17, 18.**

- Check the wiring harness for damage.

*NOTE: Before checking the wiring harness, check the intermediate connector B-01 and repair it if necessary.*

**Q: Is the check result normal?**

- YES :** Go to Step 20.  
**NO :** Repair the wiring harness.

**STEP 13. Heater controller (A/C-ECU) M.U.T.-III service data**

Check that the following service data display contents are normal.

- Item 24: Engine coolant TEMP. sensor

**Q: Is the check result normal?**

- YES :** Go to Step 17.  
**NO :** Go to Step 14.

**STEP 14. Connector check: B-20 heater water temperature connector**

**Q: Is the check result normal?**

- YES :** Go to Step 15.  
**NO :** Repair the damaged connector.

<Correct>

---

**STEP 15. Check the wiring harness between B-20 heater water temperature sensor connector terminal No. 1, 2 and B-115 heater controller (A/C-ECU) connector terminal No. 38 and B-116 heater controller (A/C-ECU) connector terminal No. 11.**

- Check the wiring harness for damage.

**Q: Is the check result normal?**  
**YES :** Go to Step 16.  
**NO :** Repair the wiring harness.

---

**STEP 16. Check the heater water temperature sensor.**

Refer to .

**Q: Is the check result normal?**  
**YES :** Intermittent malfunction. (Refer to GROUP 00 – How to Use Troubleshooting/ Inspection Service Points, How to Cope with Intermittent Malfunctions .)  
**NO :** Replace the heater water temperature sensor.

---

**STEP 17. Connector check: A-113 EV water PTC heater connector**

**Q: Is the check result normal?**  
**YES :** Go to Step 18.  
**NO :** Repair the damaged connector.

---

**STEP 18. Connector check: C-115 A/C control unit connector**

**Q: Is the check result normal?**

**YES :** Go to Step 19.  
**NO :** Repair the damaged connector.

---

**STEP 19. Check the wiring harness between A-113 EV water PTC heater connector terminal No. 6, 7, 8, 1, 2, 3, 4, 5 and C-115 A/C control unit connector terminal No. 25, 33, 34, 35, 36.**

- Check the heater drive circuit for short to earth.

*NOTE: Before checking the wiring harness, check the intermediate connector B-01 and repair it if necessary.*

**Q: Is the check result normal?**  
**YES :** Go to Step 20.  
**NO :** Repair the wiring harness.

---

**STEP 20. Check whether the diagnosis code is reset.**

**Q: Is the diagnosis code set?**  
**YES :** Go to Step 21.  
**NO :** Intermittent malfunction. (Refer to GROUP 00 – How to Use Troubleshooting/ Inspection Service Points, How to Cope with Intermittent Malfunctions .)

---

**STEP 21. After replacing the A/C control unit check again if the diagnosis code is set.**

**Q: Is the diagnosis code set?**  
**YES :** Replace the heater.  
**NO :** This diagnosis is complete.

<Correct>